



[www.boteli.com](http://www.boteli.com)

# API VALVES

## CATENA



CHINA BOTELI VALVE GROUP

# CONTENTS



## Valve ordering notice

Product type Explanation	01
Cast steel valve spec sheet	02

## Gate valve

Z40 <sup>H</sup> <sub>Y</sub> Type	04-06
PZ <sup>5</sup> <sub>9</sub> 41Y Type	07-08

## Globe valve

J41 <sup>H</sup> <sub>Y</sub> Type	10-12
PJ <sup>5</sup> <sub>9</sub> 41Y Type	13-14
PYJ <sup>5</sup> <sub>9</sub> 41 Type	15-17

## Check valve

H44H Type	19-21
PH64Y Type	22-23
PYH61Y Type	24-26
PYH64Y Type	27-29
H76H Type	30-32
H74H Type	33-34

## Strainer

Y- strainer	36-37
-------------	-------

## Bellow valve

Bellow gate valve WZ40H Type	39-40
Bellow globe valve WJ41H Type	41-42

## Cryogenic valve

Cryogenic gate valve DZ40Y Type	44-46
Cryogenic globe valve DJ41Y Type	47-48

Special features	49-50
------------------	-------

Material performance sheet	51
----------------------------	----

Pressure temperature rate	52-54
---------------------------	-------

Butt-welding ends	55
-------------------	----

Flange dimensions	56-57
-------------------	-------

Ring joint facings	58-59
--------------------	-------

# Valve Ordering Notice



## PRODUCT TYPE EXPLANATION

It is not necessary for you to know product type, if you want need offer valve, you only need to give whole requirements of you, our seller will realize it into digital date according you requirements. The first information should be give is valve type and the same time, normal diameter and pressure class, face to face dimension and sealing face material the material of sealing face also should be give.

We give example in order to know the meaning of digital. If you need more information, please contact with us.

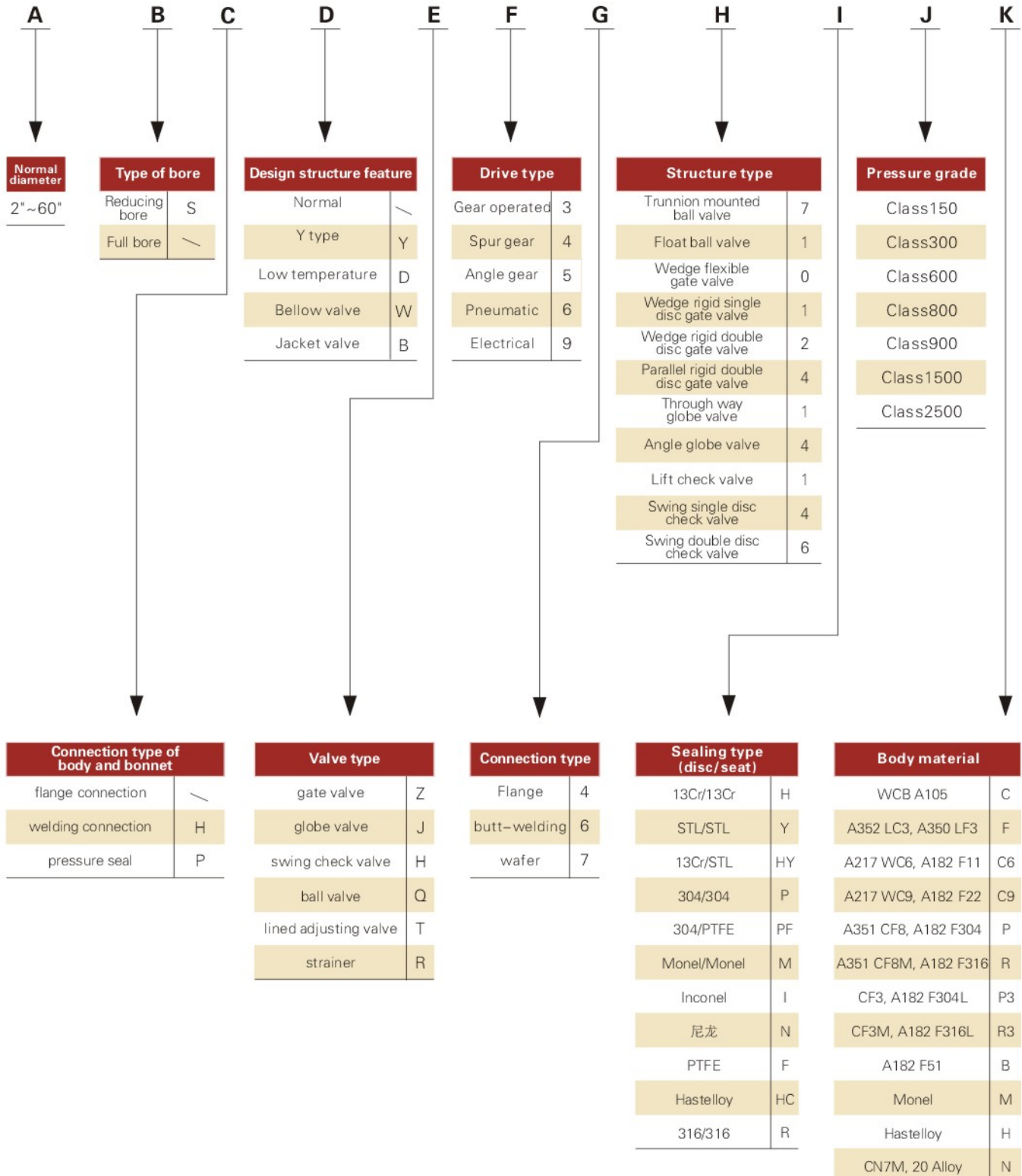

# Globe Valve



## J41H TYPE

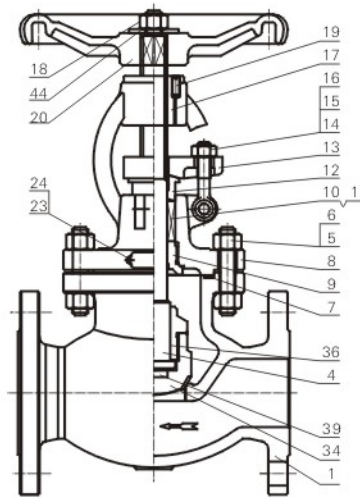

### MAIN PARTS MATERIAL SHEET

Item	Part name	WCB	C5	WC6	CF8	CF8M
1	Body	A216 WCB	A217 C5	A217 WC6	A351 CF8	A351 CF8M
4	Stem	A182 F6a	A182 F6a	A182 F6a	A182 F6a	A479 316
5	Bolt	A193 B7	A193 B7	A193 B7	A193 B8	A193 B8M
6	Nut	A194 2H	A194 2H	A194 2H	A194 8	A194 8M
7	Gasket 150Lb	Graphite				Graphite sheet
	Gasket 300Lb	304+flexible graphite				Spiral wound
	Gasket ≥600Lb	F304				Spiral wound
8	Bonnet	A216 WCB	A217 C5	A217 WC6	A351 CF8	A351 CF8M
9	Backseat	A182 F6a	A182 F6a	A182 F6a	A182 F304	A182 F316
10	Packing	304+flexible graphite				Pillar 6610+6528
11	Distance ring	A182 F6a	A182 F6a	A182 F6a	A182 F304	A182 F316
12	Packing gland	A182 F6a	A182 F6a	A182 F6a	A182 F304	A182 F316
13	Packing plate	A216 WCB	A216 WCB	A216 WCB	A351 CF8	A351 CF8
14	Eye bolt	A193 B7	A193 B7	A193 B7	A193 B7	A193 B8
15	Nut	A194 2H	A194 2H	A194 2H	A194 2H	A194 8
16	Pin	1035	1035	1035	304	304
17	Stem nut	A439 Type D2	A439 Type D2	A439 Type D2	A439 Type D2	A439 Type D2
18	Locking nut	1035	1035	1035	1035	1035
19	Locking screw	1035	1035	1035	1035	1035
20	Hand wheel	AISI 1118	AISI 1118	AISI 1118	AISI 1118	AISI 1118
23	Nameplate	AISI 304	AISI 304	AISI 304	AISI 304	AISI 304
24	Rivet	AL	AL	AL	AL	AL
34	Disc	A105/STL.6	A335-P5/STL.6	A182 F11/STL.6	A182 F304	A182 F316
36	Disc cover	1035	304	304	304	316
39	垫块	410	410	410	304	304
44	washer	1035	1035	1035	1035	1035

Note: the distance ring should be installed if user require

# Globe Valves

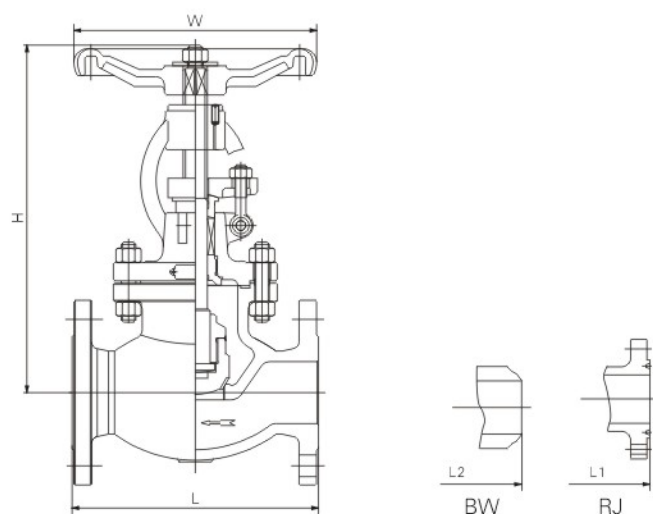

## CL150

Spec (NPS)	in	2	2 1/2	3	4	5	6	8	10	12	14	16	18	20	24
Face to face(mm)	L	203	216	241	292	356	406	495	622	698	787	914	978	978	1295
	L1	216	229	254	305	369	419	508	635	711	800	927	991	991	1308
	L2	203	216	241	292	356	406	495	622	698	787	914	978	978	1295
Center height(mm)	H	350	362	385	490	455	537	707	788	820	898	930	980	1028	1134
Hand wheel diameter(mm)	W	220	250	280	320	320	400	450	560	580	-	-	-	-	-
Weight (Kg)		21	29	34	54	72	93	185	268	400	650	1113	-	-	-

Note: when DN more than 14 inch, the way of medium flowing is form high to low (double disc)

## CL300

Spec (NPS)	in	2	2 1/2	3	4	5	6	8	10	12	14	16	18	20	24
Face to face(mm)	L	267	292	318	356	400	445	559	622	711	838	864	978	1016	1346
	L1	283	308	334	372	416	461	575	638	727	854	880	994	1035	1368
	L2	267	292	318	356	400	445	559	622	711	828	864	978	1016	1346
Center height(mm)	H	345	377	405	468	620	708	777	935	955	961	1010	1060	1100	1249
Hand wheel diameter(mm)	W	220	350	280	320	400	450	500	560	600	-	-	-	-	-
Weight (Kg)		28	36	50	75	140	200	287	510	720	-	-	-	-	-

Note: when DN more than 10 inch , the way of medium flowing is form high to low (double disc)

## CL600

Spec (NPS)	in	2	2 1/2	3	4	5	6	8	10	12	14	16
Face to face(mm)	L	292	330	356	432	508	559	660	787	838	889	991
	L1	295	333	359	435	511	562	663	790	841	892	994
	L2	292	330	356	432	508	559	660	787	838	889	991
Center height(mm)	H	385	430	475	685	770	901	913	1060	1227	1320	1540
Hand wheel diameter(mm)	W	285	280	320	400	500	550	600	650	760	-	-
Weight (Kg)		32	45	62	139	240	342	483	870	1067	-	-

Note: when DN more than 5 inch, the way of medium flowing is form high to low (double disc)

# Globe Valve

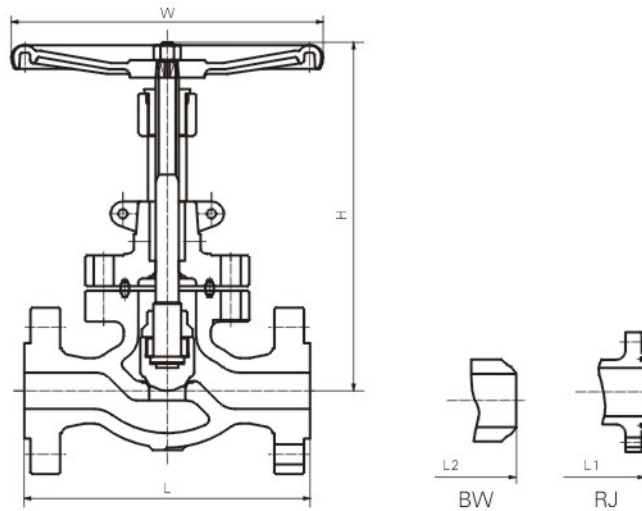

## CL900

Spec (NPS)	in	2	2 1/2	3	4	6	8	10	12	14	16
Face to face(mm)	L	368	419	381	457	610	737	838	965	1029	1130
	L2	368	419	381	457	610	737	838	965	1029	1130
	L1	371	422	384	460	613	740	841	968	1039	1140
Center height(mm)	H	430	580	675	780	870	980	1010	1300	1400	1600
Hand wheel diameter(mm)	W	320	320	350	500	850	560	-	-	-	-
Weight (Kg)		58	92	144	225	502	720	-	-	-	-

## CL1500

Spec (NPS)	in	2	2 1/2	3	4	6	8	10	12	14	16
Face to face(mm)	L	368	419	470	546	705	832	991	1130	1257	
	L1	371	422	473	549	711	842	1001	1146	1276	
	L2	368	419	470	546	705	832	991	1130	1257	
Center height(mm)	H	430	500	750	820	910	1015	1035	1350	1460	
Hand wheel diameter(mm)	W	320	400	450	600	700	800	-	-	-	
Weight (Kg)		66	115	188	292	620	808	-	-	-	

# Globe Valve



PJ<sup>5</sup><sub>9</sub> 41Y TYPE

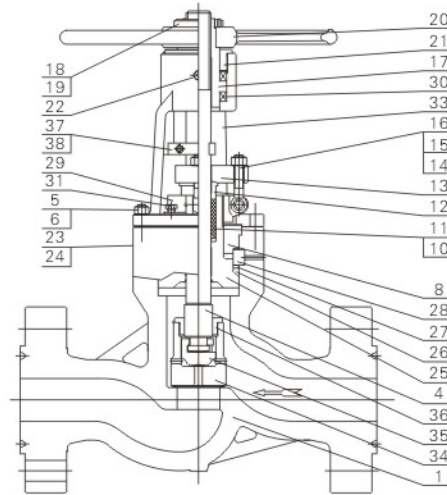

## MAIN PARTS MATERIAL SHEET

Item	Part name	WCB	WC6	WC9	CF8	CF3M	CE3MN
1	Body	A216 WCB	WC6	WC9	CF8	CF3M	CE3MN
4	Stem	A182 F6a	A182 F6a	A182 F6a	A182 F304	F316L	F53
5	Bolt	A193 B7	A193 B7	A193 B7	A193 B8	A193 B8M	A193 B8M
6	Nut	A194 2H	A194 2H	A194 2H	A194 8	A194 8M	A194 8M
8	Bonnet	A216 WCB	A216 WCB	A216 WCB	A351 Cf8	A351 Cf8	A351 Cf8
10	Packing	Flexible graphite	Flexible graphite	Flexible graphite	Flexible graphite	Flexible graphite	Flexible graphite
11	Distance ring	A182 F6a	A182 F6a	A182 F6a	A182 F304	F316L	F53
12	Packing gland	A182 F6a	A182 F6a	A182 F6a	A182 F304	F316L	F53
13	Packing plate	A216 WCB	A216 WCB	A216 WCB	A182 CF8	A182 Cf8	A182 Cf8
14	Eye bolt	A193 B7	A193 B7	A193 B7	A193 B8	Flexible graphite	Flexible graphite
15	Nut	A194 2H	A194 2H	A194 2H	A194 8	A194 8M	A194 8M
16	Pin	1035	1035	1035	304	304	304
17	Stem bolt	A439 D2	A439 D2	A439 D2	A439 D2	A439 D2	A439 D2
18	Locking nut	1035	1035	1035	1035	1035	1035
19	Locking screw	1035	1035	1035	1035	1035	1035
20	Hand wheel	AISI 1118	AISI 1118	AISI 1118	AISI 1118	AISI 1118	AISI 1118
21	Bearing gland	1035	1035	1035	1035	1035	1035
22	Oil cup	Finished product	Finished product	Finished product	Finished product	Finished product	Finished product
23	Nameplate	304	304	304	304	304	304
24	Rivet	AL	AL	AL	AL	AL	AL
25	Pressure seal seat	A216 WCB	A216 Wc6	A216 Wc9	Cf8	CF3M	CE3MN
26	Pressure seal gasket	304+flexible graphite	304+flexible graphite	304+flexible graphite	304+flexible graphite	304+flexible graphite	304+flexible graphite
27	Pressure seal ring	A182 F6a	A182 F304	A182 F304	A182 F304	A182 F316L	A182 F53
28	Segment ring	A182 F6a	A182 F11	A182 F22	A182 F304	A182 F316L	A182 F53
29	Hanger Roke	A216 WCB	A216 WCB	A216 WCB	CF8	CF8	CF8
30	Bearing	40Cr	40Cr	40Cr	40Cr	40Cr	40Cr
31	Hanger bolt	A193 B7	A193 B7	A193 B7	A193 B8	A193 B8	A193 B8
33	Roke	A216 WCB	A216 WCB	A216 WCB	CF8	CF8	CF8
34	Main disc	A105	A182 F11	A182 F22	A182 F304	A182 F316L	A182 F53
35	Auxiliary disc	A105	A182 F11	A182 F22	A182 F304	A182 F316L	A182 F53
36	Disc cover	1035	1035	1035	A182 F304	A182 F316L	A182 F53
37	Guide pad	1045	1045	1045	1045	1045	1045
38	Hex. Bolt	A193 B7	A193 B7	A193 B7	A193 B7	A193 B7	A193 B7

Note: the distance ring should be installed if user require

# Globe Valve

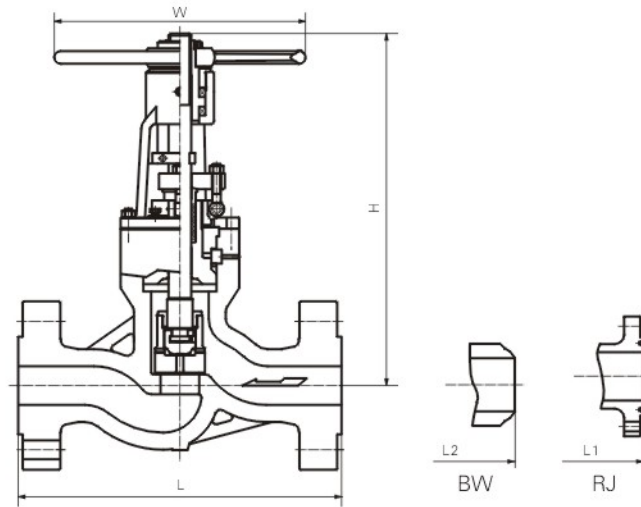

## CL900

Spec (NAP)	in	2	2 <sup>1/2</sup>	3	4	6	8	10	12	14
Face to face(mm)	L	368	419	381	457	610	737	838	965	1029
	L1	371	422	384	460	613	740	841	968	1039
	L2	216	254	305	356	508	660	787	914	990
Center height(mm)	H	457	457	457	584	825	990	1186	1320	1524
Hand wheel diameter(mm)	W	406	406	406	406	711	711	914	914	914
Weight (Kg) weld		41	41	41	90	261	437	727	1030	1534
Weight (Kg) flange		68	68	68	124	346	600	929	1324	2009

## CL1500

Spec (NAP)	in	2	2 <sup>1/2</sup>	3	4	6	8	10	12
Face to face(mm)	L	368	419	470	546	705	832	991	1130
	L1	371	422	473	549	711	842	1001	1146
	L2	216	256	305	406	559	711	864	991
Center height(mm)	H	482	482	577	685	933	1193	1270	1447
Hand wheel diameter(mm)	W	406	406	406	406	711	914	914	1066
Weight (Kg) weld		47	47	79	151	367	626	1163	1835
Weight (Kg) flange		75	75	115	208	503	852	1533	2390

## CL2500

Spec (NAP)	in	2	2 <sup>1/2</sup>	3	4	6	8	10	12
Face to face(mm)	L	451	508	578	673	914	1022	1270	1422
	L2	279	330	368	457	610	762	914	1041
	L1	454	524	584	683	927	1038	1292	1444
Center height(mm)	H	495	495	603	685	971	1200	1416	1524
Hand wheel diameter(mm)	W	406	406	406	406	711	914	1066	1066
Weight (Kg) weld		74	74	114	140	459	767	1320	1905
Weight (Kg) flange		117	117	195	260	770	1238	2222	3310



# Globe Valve



PYJ<sup>5</sup> 41Y TYPE

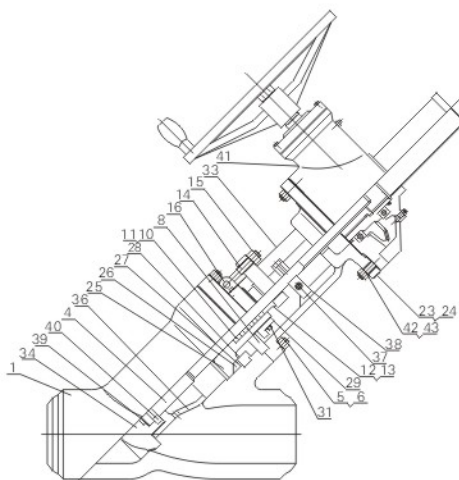

## MAIN PARTS MATERIAL SHEET

Item	Part name	WCB	C5	WC6	CF8	CF8M
1	Body	A216 WCB	A217 C5	A217 WC6	A351 CF8	A351 CF8M
4	Stem	A182 F6a	A182 F6a	A182 F6a	A182 F304	A182 F316
5	Bolt	A193 B7	A193 B7	A193 B7	A193 B8	A193 B8M
6	Nut	A194 2H	A194 2H	A194 2H	A194 8	A194 8M
8	Bonnet	A216 WCB	A216 WCB	A216 WCB	A351 CF8M	A351 CF8M
10	Packing	304+flexible graphite				Pillar 6610+6528
11	Distance ring	A182 F6a	A182 F6a	A182 F6a	A182 F304	A182 F316
12	Packing gland	A182 F6a	A182 F6a	A182 F6a	A182 F304	A182 F316
13	Packing plate	A216 WCB	A216 WCB	A216 WCB	A351 CF8	A351 CF8
14	Eye bolt	A193 B7	A193 B7	A193 B7	A193 B8	A193 B8
15	Nut	A194 2H	A194 2H	A194 2H	A194 8	A194 8
16	Pin	1035	1035	1035	304	304
23	Nameplate	AISI 304	AISI 304	AISI 304	AISI 304	AISI 304
24	Rivet	AL	AL	AL	AL	AL
25	Pressure seal seat	A216 WCB	A217 C5	A217 WC6	A351 CF8	A351 CF8M
26	Pressure seal gasket	304+flexible graphite				
27	Pressure seal ring	A182 F6a	A182 F6a	A182 F6a	A182 F304	A182 F316
28	Segment ring	A182 F6a	A182 F11	A182 F11	A182 F304	A182 F316
29	Hanger Roke	A216 WCB	A216 WCB	A216 WCB	A351 CF8	A351 CF8
31	Hanger bolt	A193 B7	A193 B7	A193 B7	A193 B8	A193 B8M
33	Roke	A216 WCB	A216 WCB	A216 WCB	A351 CF8	A351 CF8
34	Disc	A105/STL.6	A182 F11	A182 F11/STL.6	A182 F304	A182 F316
36	Disc cover	A216 WCB	A217 C5	A217 WC6	A351 CF8	A351 CF8M
37	Guide pad	1045	1045	1045	1045	1045
38	Hex. Bolt	A193 B7	A193 B7	A193 B7	A193 B7	A193 B7
39	Gasket	410	410	410	304	304
40	Split ring	410	410	410	304	316
41	Bevel gear	Finished product	Finished product	Finished product	Finished product	Finished product
42	Bolt	A193 B7	A193 B7	A193 B7	A193 B7	A193 B7
43	Nut	A194 2H	A194 2H	A194 2H	A194 2H	A194 2H

Note: the distance ring should be installed if user require

# Globe Valve

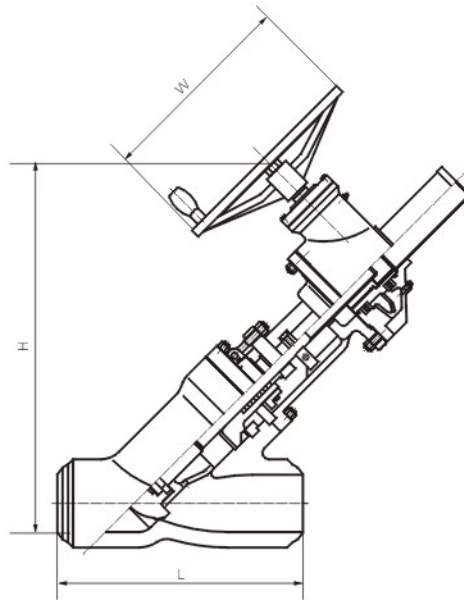

## CL600

Spec (NPS)	in	6-8	10	12	14	16
Face to face(mm)	L	584	711	813	813	1041
Center height(mm)	H	648	899	1157	1157	1956
Hand wheel diameter(mm)	W	711	914	1219	1219	1219
Weight (Kg)		372	830	1161	1161	2527

Spec (NPS)	in	10 x 8 x 10	12 x 10 x 12	14 x 12 x 14	16 x 14 x 16	18 x 16 x 18
Face to face(mm)	L	584	711	813	813	1041
Center height(mm)	H	648	899	1157	1157	1956
Hand wheel diameter(mm)	W	711	914	1219	1219	1219
Weight (Kg)		408	918	1281	1281	2778

## CL900

Spec (NPS)	in	6	8	10	12	14	16	18	20
Face to face(mm)	L	705	762	921	1041	1092	1372	1600	1384
Center height(mm)	H	1028	1356	1615	1977	1977	2276	2492	2819
Hand wheel diameter(mm)	W	711	711	914	1219	1219	1219	1829	1829
Weight (Kg)		367	709	1318	1795	1795	3495	3550	4446

Spec (NPS)	in	8 x 6 x 8	10 x 8 x 10	12 x 10 x 12	14 x 12 x 14	16 x 14 x 16	18 x 16 x 18	20 x 18 x 20	22 x 20 x 22
Face to face(mm)	L	705	762	921	1014	1092	1372	1600	1384
Center height(mm)	H	1028	1356	1615	1977	1977	2276	2492	2819
Hand wheel diameter(mm)	W	711	711	914	1219	1219	1219	1829	1829
Weight (Kg)		367	675	1305	1845	1845	3600	3600	5850

# Globe Valve

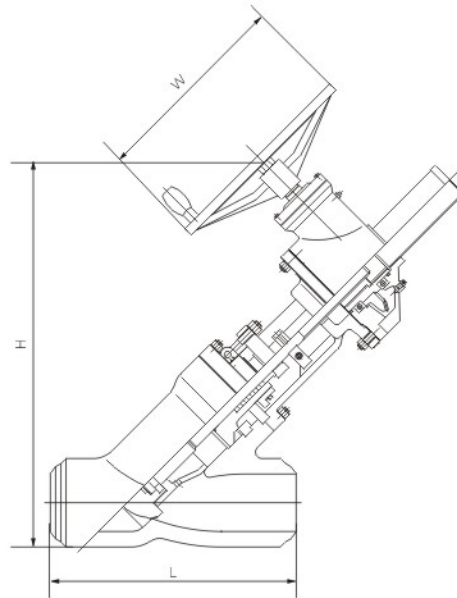

## CL1500

Spec (NPS)	in	6	8	10	12	14
Face to face(mm)	<b>L</b>	705	862	921	1041	1092
Center height(mm)	<b>H</b>	1028	1356	1615	1977	1977
Hand wheel diameter(mm)	<b>W</b>	711	711	914	1219	1219
Weight (Kg)		367	709	1318	1795	1795

Spec (NPS)	in	8 x 6 x 8	10 x 8 x 10	12 x 10 x 12	14 x 12 x 14	16 x 14 x 16
Face to face(mm)	<b>L</b>	705	765	921	1014	1092
Center height(mm)	<b>H</b>	1028	1356	1615	1977	1977
Hand wheel diameter(mm)	<b>W</b>	71	711	914	1219	1219
Weight (Kg)		404	786	1464	1991	1991

## CL2500

Spec (NPS)	in	6	8	10	12	14	16	18	20
Face to face(mm)	<b>L</b>	610	762	914	1041	1238	1238	1473	1473
Center height(mm)	<b>H</b>	1270	1381	1551	1830	1983	1983	2489	2489
Hand wheel diameter(mm)	<b>W</b>	711	711	914	914	1219	1219	1829	1829
Weight (Kg)		682	750	1348	2157	3448	3448	5136	6864

Spec (NPS)	in	8 x 6 x 8	10 x 8 x 10	12 x 10 x 12	14 x 12 x 14	16 x 14 x 16	18 x 16 x 18	20 x 18 x 20	22 x 20 x 22
Face to face(mm)	<b>L</b>	600	762	914	1014	1238	1238	1473	1473
Center height(mm)	<b>H</b>	1270	1381	1551	1830	1983	1983	2489	2489
Hand wheel diameter(mm)	<b>W</b>	711	714	1219	1219	1219	1219	1829	1829
Weight (Kg)		682	846	1482	2395	3793	3793	5455	5455

# Check Valve



Btl check valve usually be reliably used in steam, air, coal gas, oil or oil gas etc high or low–pressure condition. High or low–pressure valve normal adopt internal rocker to reduce medium external leakage. It can be equipped external lever and adjusting foundry weight and can be select connection type and trim material according to working condition if user need. Large check valve usually be equipped with vibration absorber.



## ◆ **CAST STEEL CHECK VALVE DESIGN STRUCTURE AND FEATURE**

Design and manufacture conform to ASME B 16.5 ,API 594,API 6D & BS 1868  
Test and check conform to API 598.

### ◆ **ADOPT THE FOLLOWING STRUCTURE**

Inside rocker  
Renewable seat  
Bolted bonnet, spiral would eight–square gasket sealing bonnet or pressure seal bonnet

### ◆ **ACCORDING TO THE FOLLOWING STANDARD**

Flange ends conform to ASME B 16.5  
Butt–welding end conform to ASME B 16.25  
Face to face dimension conform to ASME B 16.10

# Check Valve



## H44H TYPE

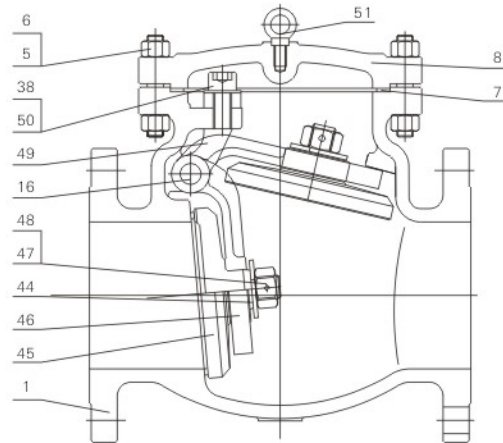

### MAIN PARTS MATERIAL SHEET

Item	Part name	WCB	LCC	C5	C12	WC6	CF8M
1	Body	A216 WCB	A352 LCC	A217 C5	A217 C12	A217 WC6	A351 CF8M
5	Bolt	A193 B7	A320 L7M	A193 B7	A193 B7	A193 B7	A193 B8M
6	Nut	A194 2H	A194 7M	A194 2H	A194 2H	A194 2H	A194 8M
	Gasket 150Lb	Graphite					316+graphite
7	Gasket 300Lb	304+flexible graphite					Spiral wound
	Gasket ≥600Lb	F304					Spiral wound
8	Bonnet	A216 WCB	A352 LCC	A217 C5	A217 C12	A217 WC6	A351 CF8M
16	Pin	410	410	410	410	410	304
38	Hex. Bolt	A193 B8	A193 B8	A193 B8	A193 B8	A193 B8	A193 B8
44	Washer	410	410	410	410	410	304
45	Disc	A105/STL.6	A350 LF2/STL.6	A335-P5/STL.6	AISI 321/STL.6	A182 F11/STL.6	A182 F316
46	Rocker	A216 WCB	A352 LCC	A217 C5	A217 C12	A217 WC6	A351 CF8M
47	Nut	410	410	410	410	410	304
48	Pin	304	304	304	304	304	304
49	Roke	A216 WCB	A352 LCC	A217 C5	A217 C12	A217 WC6	A351 CF8M
50	Flexible washer	17-4PH	17-4PH	17-4PH	17-4PH	17-4PH	17-4PH
51	Hanger screw	A193 B8	A193 B8	A193 B8	A193 B8	A193 B8	A193 B8

# Valve ordering noteice



## CAST STEEL VALVE SPEC SHEET

Name		Specification (in)																								
Gate series	Type	CL	2	2 1/2	3	4	5	6	8	10	12	14	16	18	20	24	26	28	30	32	36	40	48	54	56	60
	Gate series	Z40H/Y	150	✓	✓	✓	✓	✓	✓	✓	✓	✓	✓	✓	✓	✓	✓	✓	✓	✓	✓	✓	✓	✓	✓	✓
300		✓	✓	✓	✓	✓	✓	✓	✓	✓	✓	✓	✓	✓	✓	✓	✓	✓	✓	✓	✓	✓	✓	✓	✓	✓
600		✓	✓	✓	✓	✓	✓	✓	✓	✓	✓	✓	✓	✓	✓	✓	✓	✓	✓	✓	✓	✓	✓	✓	✓	✓
900		✓	✓	✓	✓	✓	✓	✓	✓	✓	✓	✓	✓	✓	✓	✓	✓	✓	✓	✓	✓	✓	✓	✓	✓	✓
1500		✓	✓	✓	✓	✓	✓	✓	✓	✓	✓	✓	✓	✓	✓	✓	✓	✓	✓	✓	✓	✓	✓	✓	✓	✓
Globe series	PZ541Y	150	✓	✓	✓	✓	✓	✓	✓	✓	✓	✓	✓	✓	✓	✓	✓	✓	✓	✓	✓	✓	✓	✓	✓	✓
	300	✓	✓	✓	✓	✓	✓	✓	✓	✓	✓	✓	✓	✓	✓	✓	✓	✓	✓	✓	✓	✓	✓	✓	✓	✓
	600	✓	✓	✓	✓	✓	✓	✓	✓	✓	✓	✓	✓	✓	✓	✓	✓	✓	✓	✓	✓	✓	✓	✓	✓	✓
	900	✓	✓	✓	✓	✓	✓	✓	✓	✓	✓	✓	✓	✓	✓	✓	✓	✓	✓	✓	✓	✓	✓	✓	✓	✓
	1500	✓	✓	✓	✓	✓	✓	✓	✓	✓	✓	✓	✓	✓	✓	✓	✓	✓	✓	✓	✓	✓	✓	✓	✓	✓
Check valve series	H44H/Y	150	✓	✓	✓	✓	✓	✓	✓	✓	✓	✓	✓	✓	✓	✓	✓	✓	✓	✓	✓	✓	✓	✓	✓	✓
	300	✓	✓	✓	✓	✓	✓	✓	✓	✓	✓	✓	✓	✓	✓	✓	✓	✓	✓	✓	✓	✓	✓	✓	✓	✓
	600	✓	✓	✓	✓	✓	✓	✓	✓	✓	✓	✓	✓	✓	✓	✓	✓	✓	✓	✓	✓	✓	✓	✓	✓	✓
	900	✓	✓	✓	✓	✓	✓	✓	✓	✓	✓	✓	✓	✓	✓	✓	✓	✓	✓	✓	✓	✓	✓	✓	✓	✓
	1500	✓	✓	✓	✓	✓	✓	✓	✓	✓	✓	✓	✓	✓	✓	✓	✓	✓	✓	✓	✓	✓	✓	✓	✓	✓
Low temperature series	DZ40Y	150	✓	✓	✓	✓	✓	✓	✓	✓	✓	✓	✓	✓	✓	✓	✓	✓	✓	✓	✓	✓	✓	✓	✓	✓
	300	✓	✓	✓	✓	✓	✓	✓	✓	✓	✓	✓	✓	✓	✓	✓	✓	✓	✓	✓	✓	✓	✓	✓	✓	✓
	600	✓	✓	✓	✓	✓	✓	✓	✓	✓	✓	✓	✓	✓	✓	✓	✓	✓	✓	✓	✓	✓	✓	✓	✓	✓
	900	✓	✓	✓	✓	✓	✓	✓	✓	✓	✓	✓	✓	✓	✓	✓	✓	✓	✓	✓	✓	✓	✓	✓	✓	✓
	1500	✓	✓	✓	✓	✓	✓	✓	✓	✓	✓	✓	✓	✓	✓	✓	✓	✓	✓	✓	✓	✓	✓	✓	✓	✓
Strainer series	DJ41Y	150	✓	✓	✓	✓	✓	✓	✓	✓	✓	✓	✓	✓	✓	✓	✓	✓	✓	✓	✓	✓	✓	✓	✓	✓
	300	✓	✓	✓	✓	✓	✓	✓	✓	✓	✓	✓	✓	✓	✓	✓	✓	✓	✓	✓	✓	✓	✓	✓	✓	✓
	600	✓	✓	✓	✓	✓	✓	✓	✓	✓	✓	✓	✓	✓	✓	✓	✓	✓	✓	✓	✓	✓	✓	✓	✓	✓
	900	✓	✓	✓	✓	✓	✓	✓	✓	✓	✓	✓	✓	✓	✓	✓	✓	✓	✓	✓	✓	✓	✓	✓	✓	✓
	1500	✓	✓	✓	✓	✓	✓	✓	✓	✓	✓	✓	✓	✓	✓	✓	✓	✓	✓	✓	✓	✓	✓	✓	✓	✓
Basket type	150	1/2	3/4	1	1 1/2	2	2 1/2	3	4	6	8															
	300	✓	✓	✓	✓	✓	✓	✓	✓	✓	✓	✓	✓	✓	✓	✓	✓	✓	✓	✓	✓	✓	✓	✓	✓	✓
	600	✓	✓	✓	✓	✓	✓	✓	✓	✓	✓	✓	✓	✓	✓	✓	✓	✓	✓	✓	✓	✓	✓	✓	✓	✓
	150	✓	✓	✓	✓	✓	✓	✓	✓	✓	✓	✓	✓	✓	✓	✓	✓	✓	✓	✓	✓	✓	✓	✓	✓	✓
	300	✓	✓	✓	✓	✓	✓	✓	✓	✓	✓	✓	✓	✓	✓	✓	✓	✓	✓	✓	✓	✓	✓	✓	✓	✓

# Check Valve

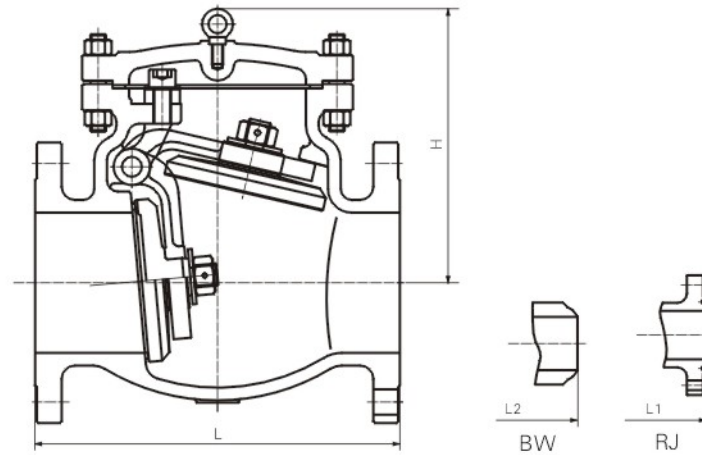

## CL150

Spec (NAP)	in	2	2 1/2	3	4	5	6	8	10	12	14	16	18	20	24	28	30
Face to face(mm)	L	203	216	241	292	330	356	495	622	698	787	864	978	978	1295	1448	1524
	L1	216	229	254	305	343	369	508	635	711	800	877	991	991	1308	-	-
	L2	203	216	241	292	330	356	495	622	699	787	864	978	978	1295	1448	1524
Center height(mm)	H	145	160	180	210	250	292	360	400	465	524	620	690	720	740	850	1005
Weight (Kg)		17	20	25	40	67	93	134	199	305	370	542	750	900	1200	1750	2100

## CL300

Spec (NAP)	in	2	2 1/2	3	4	5	6	8	10	12	14	16	18	20	24	28	30
Face to face(mm)	L	267	292	318	356	400	444	533	622	711	838	864	978	1016	1346		
	L1	283	308	334	372	416	460	549	638	727	854	880	994	1035	1368		
	L2	267	292	318	356	400	444	533	622	711	838	864	978	1016	1346		
Center height(mm)	H	158	180	200	228	285	315	385	432	490	552	625	676	742	810		
Weight (Kg)		23	37	46	71	100	118	202	296	428	583	754	935	1155	1408		

## CL600

Spec (NAP)	in	2	2 1/2	3	4	5	6	8	10	12	14	16	18	20	24	28	30
Face to face(mm)	L	292	330	356	432	508	559	660	787	838	889	991	1092	1194	1397		
	L1	295	333	359	435	511	562	663	790	841	892	994	1095	1200	1407		
	L2	292	330	356	432	508	559	660	787	838	889	991	1092	1194	1397		
Center height(mm)	H	170	188	238	290	325	355	415	478	540	580	670	786	845	940		
Weight (Kg)		26	32	49	86	165	252	429	557	670	944	1300	1760	2200	2864		

# Check Valve

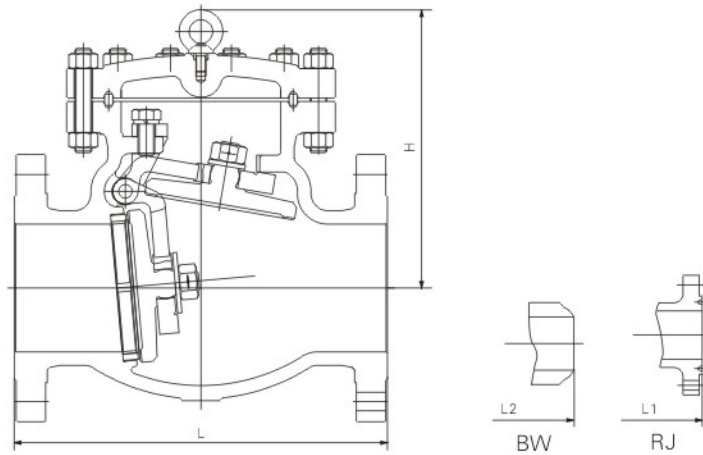

## CL900

Spec (NAP)	in	2	2 1/2	3	4	5	6	8	10	12	14	16	18	20	24	
Face to face(mm)	L	368	419	381	457	559	610	737	838	965	1029	1130				
	L1	371	422	384	460	562	613	740	841	968	1039	1140				
	L2	368	419	381	457	559	610	737	838	965	1059	1130				
Center height(mm)	H	200	260	285	324	370	424	522	545	590	640	700				
Weight (Kg)		58	76	100	140	217	294	700	724	870	1254	1800				

## CL1500

Spec (NAP)	in	2	2 1/2	3	4	5	6	8	10	12	14	16	18	20	24	
Face to face(mm)	L	368	419	470	546	673	705	832	991	1130	1257	1384				
	L1	371	422	473	549	676	711	842	1001	1146	1276	1406				
	L2	368	419	470	546	673	705	832	991	1130	1257	1384				
Center height(mm)	H	200	270	285	353	402	470	561	660	750	850	955				
Weight (Kg)		66	84	123	192	320	481	760	1058	1440	1745	2500				



# Check Valve



## PH64Y TYPE

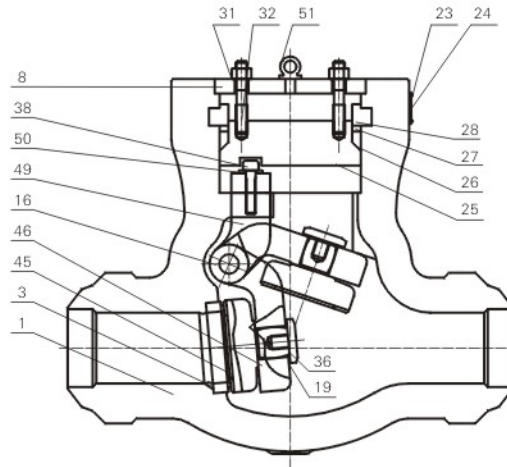

### MAIN PARTS MATERIAL SHEET

Item	Part name	WCB	WC6	WC9	CF8	CF8M
1	Body	A216 WCB	A217 WC6	A217 WC9	A351 CF8	A351 CF8M
3	seat	A105/STL.6	A182 F11/STL.6	A182 F22/STL.6	A182 F304	A182 F316
8	Bonnet	A216 WCB	A216 WCB	A216 WCB	A351 CF8	A351 CF8
16	Pin	A276 410	A276 304	A276 304	A276 304	A276 316
19	止定螺钉	A193 B8	A193 B8	A193 B8	A193 B8	A193 B8
23	Nameplate	AISI 304	AISI 304	AISI 304	AISI 304	AISI 304
24	Rivet	AL	AL	AL	AL	AL
25	Pressure seal seat	A105	A182 F11	A182 F22	A182 F304	A182 F316
26	Pressure seal gasket	304+flexible graphite				
27	Pressure seal ring	A182 F6a	A182 F6a	A182 F6a	A182 F304	A182 F316
28	Segment ring	A182 F6a	A182 F11	A182 F22	A182 F304	A182 F316
31	Hanger bolt	A193 B7	A193 B7	A193 B7	A193 B8	A193 B8
32	Nut	A194 2H	A194 2H	A194 2H	A194 8	A194 8
36	Disc cover	A182 F6a	A182 F304	A182 F304	A182 F304	A182 F304
38	Hex. Bolt	A193 B8	A193 B8	A193 B8	A193 B8	A193 B8
45	Disc	A105/STL.6	A182 F11/STL.6	A182 F22/STL.6	A182 F304	A182 F316
46	Rocker	A216 WCB	A217 WC6	A217 WC9	A351 CF8	A351 CF8M
49	Roke	A216 WCB	A217 WC6	A217 WC9	A351 CF8	A351 CF8M
50	Flexible washer	17-4PH	17-4PH	17-4PH	17-4PH	17-4PH
51	Hanger screw	A193 B7	A193 B7	A193 B7	A193 B7	A193 B7

# Check Valve

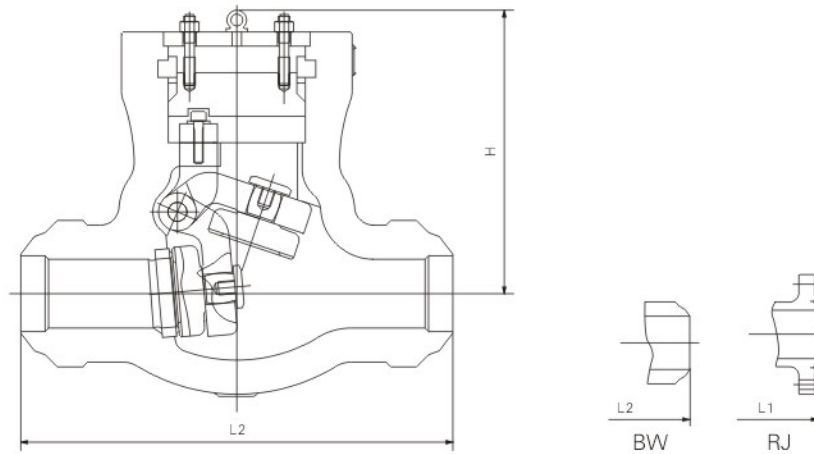

## CL900

Spec (NAP)	in	2	2 1/2	3	4	6	8	10	12	14	16
Face to face(mm)	L	368	419	381	457	610	737	838	965	1029	1130
	L1	371	422	384	460	613	740	841	968	1039	1140
	L2	216	254	305	356	508	660	787	914	991	1092
Center height(mm)	H	215	245	292	318	400	464	517	592	640	700
Weight (Kg)		25	35	46	68	170	460	700	1020	1220	1350

## CL1500

Spec (NAP)	in	2	2 1/2	3	4	6	8	10	12	14	16
Face to face(mm)	L	368	419	470	546	705	832	991	1130	1257	1384
	L1	371	422	473	549	711	842	1001	1146	1276	1406
	L2	216	254	305	406	559	711	864	991	1067	1194
Center height(mm)	H	245	265	300	342	438	534	578	648	700	770
Weight (Kg)		26	36	50	80	290	490	750	1110	1415	1605

## CL2500

Spec (NAP)	in	2	2 1/2	3	4	6	8	10	12	14	16
Face to face(mm)	L	451	508	578	673	914	1022	1270	1422		
	L1	454	514	584	683	927	1038	1292	1445		
	L2	279	330	368	457	610	762	914	1041		
Center height(mm)	H	250	280	308	352	440	540	580	660		
Weight (Kg)		60	85	100	165	460	900	1300	1800		

# Check Valve

## PYH61Y TYPE

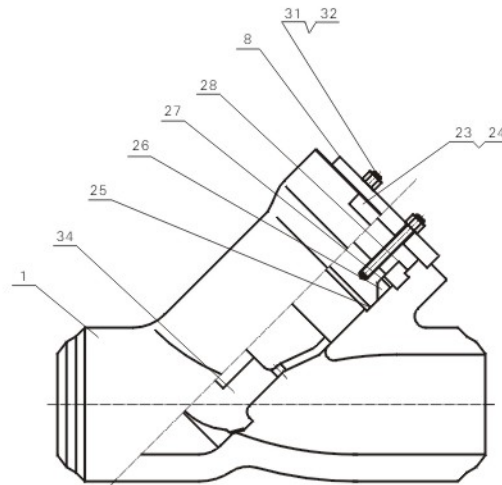

### MAIN PARTS MATERIAL SHEET

Item	Part name	WCB	WC6	WC9	CF8	CF3M	CE3MN
1	Body	A216 WCB	A217 WC6	A217 WC9	A351 CF8	A351 CF3M	CE3MN
8	Bonnet	A216 WCB	A216 WCB	A216 WCB	A351 CF8	A351 CF8	A351 CF8
23	Nameplate	AISI 304	AISI 304	AISI 304	AISI 304	AISI 304	AISI 304
24	Rivet	AL	AL	AL	AL	AL	AL
25	Pressure seal seat	A105	A182 F11	A182 F22	A182 F304	A182 F316L	A182 F53
26	Pressure seal gasket	304+flexible graphite					
27	Pressure seal ring	A182 F6a	A182 F6a	A182 F6a	A182 F304	A182 F316L	A182 F53
28	Segment ring	A182 F6a	A182 F11	A182 F22	A182 F304	A182 F316L	A182 F53
31	Hanger bolt	A193 B7	A193 B7	A193 B7	A193 B8	A193 B8M	A193 B8M
32	Nut	A194 2H	A194 2H	A194 2H	A194 8	A194 8M	A194 8M
34	Disc	A105	A182 F11	A182 F22	A182 F304	A182 F316L	A182 F53

# Check Valve

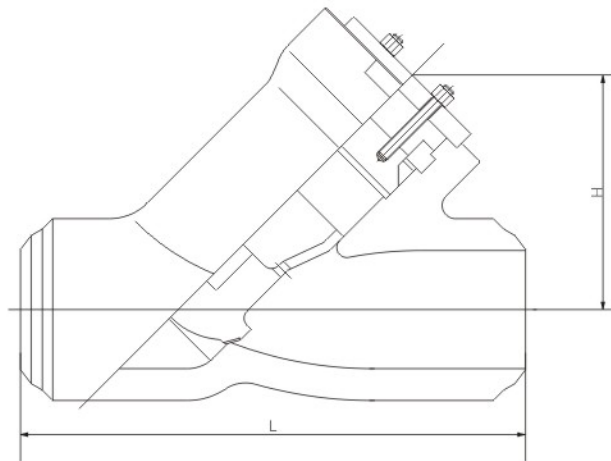

## CL600

Spec (NAP)	in	6	8	10	12	14	16	18	20
Face to face(mm)	L	457	584	711	813	813	1041	1041	1524
Center height(mm)	H	406	508	635	822	822	1054	1054	1194
Weight (Kg)		182	272	454	658	658	1270	1270	1588

Spec (NAP)	in	8 x 6 x 8	10 x 8 x 10	12 x 10 x 12	14 x 12 x 14	16 x 14 x 16	18 x 16 x 18	20 x 18 x 20	22 x 20 x 22
Face to face(mm)	L	457	584	711	813	813	1041	1041	1524
Center height(mm)	H	406	508	635	822	822	1054	1054	1194
Weight (Kg)		182	303	506	724	724	1397	1397	1770

## CL900

Spec (NAP)	in	6	8	10	12	14
Face to face(mm)	L	705	762	921	1041	1092
Center height(mm)	H	457	598	716	891	891
Weight (Kg)		182	284	527	718	718

Spec (NAP)	in	8 x 6 x 8	10 x 8 x 10	12 x 10 x 12	14 x 12 x 14	16 x 14 x 16
Face to face(mm)	L	705	762	921	1041	1092
Center height(mm)	H	457	598	716	891	891
Weight (Kg)		182	316	582	795	794

# Check Valve

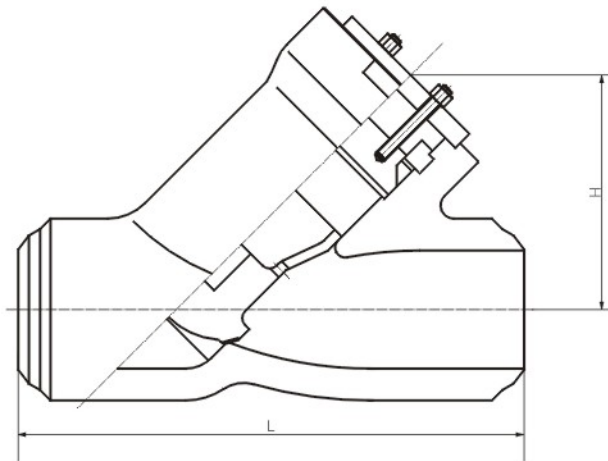

## CL1500

Spec (NAP)	in	6	8	10	12	14	16	18	20
Face to face(mm)	L	705	762	921	1041	1092	1372	1600	1600
Center height(mm)	H	457	598	716	891	891	1129	1129	1129
Weight (Kg)		182	284	527	718	718	1397	1420	1782

Spec (NAP)	in	8 x 6 x 8	10 x 8 x 10	12 x 10 x 12	14 x 12 x 14	16 x 14 x 16	18 x 16 x 18	20 x 18 x 20	22 x 20 x 22
Face to face(mm)	L	705	762	921	1041	1092	1372	1600	1384
Center height(mm)	H	457	598	716	891	891	1129	1129	1332
Weight (Kg)		182	316	582	795	794	1534	1560	1977

## CL2500

Spec (NAP)	in	6	8	10	12	14
Face to face(mm)	L	610	762	914	1041	1238
Center height(mm)	H	521	612	761	879	948
Weight (Kg)		245	300	585	863	1380

Spec (NAP)	in	8 x 6 x 8	10 x 8 x 10	12 x 10 x 12	14 x 12 x 14	16 x 14 x 16
Face to face(mm)	L	610	762	914	1041	1238
Center height(mm)	H	521	612	761	879	948
Weight (Kg)		245	329	594	595	1530

# Check Valve



## PYH64Y TYPE

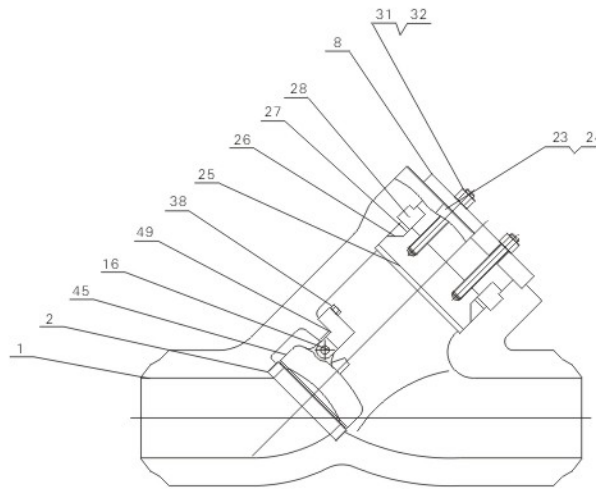

### MAIN PARTS MATERIAL SHEET

Item	Part name	WCB	WC6	WC9	CF8	CF3M	CE3MN
1	Body	A216 WCB	A217 WC6	A217 WC9	A351 CF8	A351 CF3M	CE3MN
2	Seat	A105	A182 F11	A182 F22	A182 F304	A182 F316L	A182 F53
8	Bonnet	A216 WCB	A216 WCB	A216 WCB	A351 CF8	A351 CF8	A351 CF8
16	Pin	A276 410	A276 410	A276 410	A276 304	A276 316L	A276 F53
23	Nameplate	AISI 304	AISI 304	AISI 304	AISI 304	AISI 304	AISI 304
24	Rivet	AL	AL	AL	AL	AL	AL
25	Pressure seal seat	A105	A182 F11	A182 F22	A182 F304	A182 F316L	A182 F53
26	Pressure seal gasket	304+flexible graphite					
27	Pressure seal ring	A182 F6a	A182 F6a	A182 F6a	A182 F304	A182 F316L	A182 F53
28	Segment ring	A182 F6a	A182 F11	A182 F22	A182 F304	A182 F316L	A182 F53
31	Hanger bolt	A193 B7	A193 B7	A193 B7	A193 B8	A193 B8M	A193 B8M
32	Nut	A194 2H	A194 2H	A194 2H	A194 8	A194 8M	A194 8M
45	Disc	A105	A182 F11	A182 F22	A182 F304	A182 F316L	A182 F53
49	Roke	A216 WCB	A217 WC6	A217 WC9	A351 CF8	A351 CF3M	CE3MN

# Check Valve

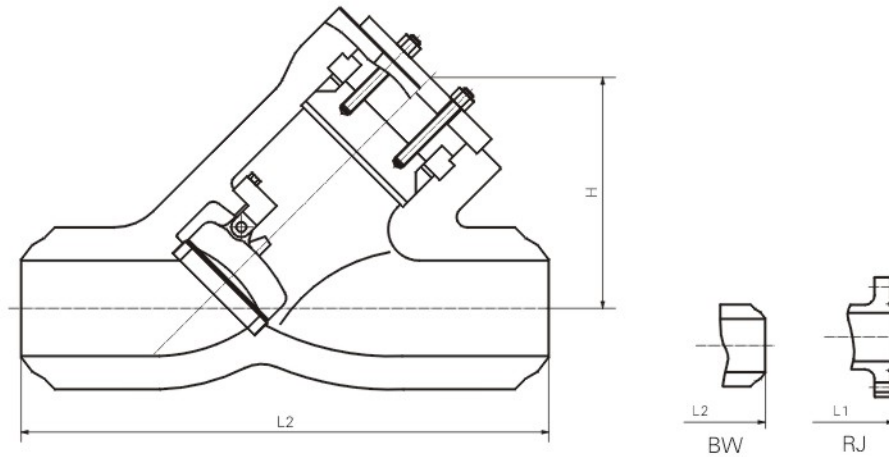

## CL900

Spec (NAP)	in	2	2.5	3	4	6	8	10	12	14	16	18	20
Face to face(mm)	L	254	254	304	355	508	660	787	914	990	1092	1219	1320
	L1	381	381	381	457	609	736	838	965	1028	1130	1219	1320
	L2	384	384	384	460	612	739	841	968	1039	1140	1232	1333
Center height(mm)	H	190	190	190	190	241	304	381	419	457	501	596	660
Weight (Kg) weld		20	20	20	23	59	109	213	326	408	589	834	1102
Weight (Kg) flange		50	50	50	68	159	276	473	662	907	1179	1655	2143

Spec (NAP)	in	8 x 6 x 8	10 x 8 x 10	12 x 10 x 12	14 x 12 x 14	16 x 14 x 16	18 x 16 x 18	20 x 18 x 20
Face to face(mm)	L	609	736	838	965	1028	1130	1219
Center height(mm)	H	241	304	381	419	457	501	596
Weight (Kg)		63	113	219	335	421	612	857

## CL1500

Spec (NAP)	in	2	2.5	3	4	6	8	10	12
Face to face(mm)	L	254	254	304	406	558	711	863	990
	L1	469	469	469	546	704	831	990	1130
	L2	473	473	473	549	711	841	1000	1146
Center height(mm)	H	196	196	196	215	266	342	419	469
Weight (Kg) weld		25	25	25	36	91	182	326	499
Weight (Kg) flange		68	68	68	99	235	424	725	1088

Spec (NAP)	in	8 x 6 x 8	10 x 8 x 10	12 x 10 x 12	14 x 12 x 14
Face to face(mm)	L	705	831	990	1130
Center height(mm)	H	266	342	419	469
Weight (Kg)		99	195	340	517

# Check Valve

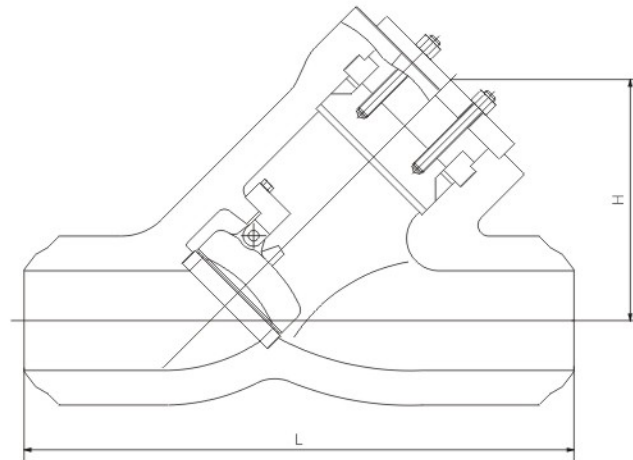

## CL2500

Spec (NAP)	in	2	2.5	3	4	6	8	10	12	14	16	18	20
Face to face(mm)	L	330	330	368	457	610	762	914	1041	1117	1219	1346	1447
Center height(mm)	H	203	203	203	304	330	406	457	533	584	660	711	787
Weight (Kg) weld		36	26	26	50	145	281	520	725	975	1247	1587	1927
Weight (Kg) flange		113	113	113	159	445	694	1429	2068	2227	2590	2864	3272

Spec (NAP)	in	8 x 6 x 8	10 x 8 x 10	12 x 10 x 12	14 x 12 x 14	16 x 14 x 16	18 x 16 x 18	20 x 18 x 20
Face to face(mm)	L	711	863	1009	1041	1117	1244	1511
Center height(mm)	H	330	406	457	533	584	660	711
Weight (Kg)		154	290	544	752	1011	1292	1950





# Gate Valves



## ◆ CAST STEEL GATE VALVE DESIGN STRUCTURE AND FEATURE

Design and manufacture conform to API 600, API 6D & ASME B 16.34 Test and check conform to API 598.

## ◆ ADOPT THE FOLLOWING STRUCTURE

Full bore

Flexible or rigid disc or soft seal structure

Self-centering gland or plate Renewable seat

Bolted bonnet, spiral wouled eight-square gasket

sealing bonnet or pressure seal bonnet

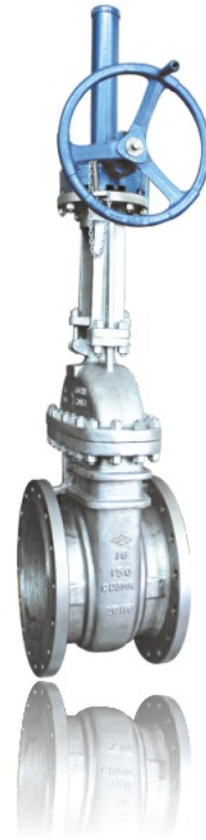

## ◆ ACCORDING TO THE FOLLOWING STANDARD

Flange ends conform to ASME B 16.5& ASME B 16.47A

Butt-welding end conform to ASME B 16.25

Face to face dimension conform to ASME B 16.10, API 600, API 6D

Operation type: electrical, pneumatic, hydraulic and gear etc

# Check Valve



## H76H TYPE

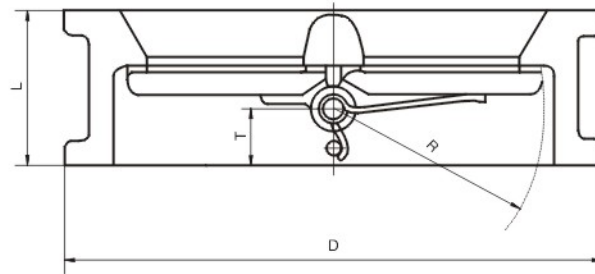

In order to settle the problem that exist in traditional valve, our company based on API and DIN standard and combine with our company many year's experiment in valve design field to develop wafer double swing check valve and wafer lift check valve series products that have be wildly used in petrochemical, metallurgy, power station, light industry, food etc field.

### STRUCTURE FEATURE

- 1、 Structure more Shorten
- 2、 Volumes more small and weight more light
- 3、 Quickly close and water hammer small
- 4、 Easy to be installed in vertical or horizontal
- 5、 Little Flow instance
- 6、 Action quick and sealing performance well
- 7、 Longer using life and more realizabe



### MAIN PARTS MATERIAL SHEET

Item	Part name	WCB	CF8	CF3	CF3M	CE3MN
1	Body	A216 WCB	A351 Cf8	A351 Cf3	A351 CF3M	A351 CE3MN
7	Gasket	Graphite	Graphite	Graphite	Graphite	Graphite
8	Hinge pin	410	304	304L	316L	F53
23	Nameplate	304	304	304	304	304
24	Rivet	AL	AL	AL	AL	AL
50	Hex. Bolt	A193 B8	A193 B8	A193 B8	A193 B8M	A193 B8M
51	Hanger screw	A193 B7	A193 B7	A193 B7	A193 B7	A193 B7
53	Spring	17-4PH	17-4PH	17-4PH	17-4PH	Inconel
54	Disc	A351 CF8	A351 CF8	A351 CF3	A351 CF3M	CE3MN

# Check Valve

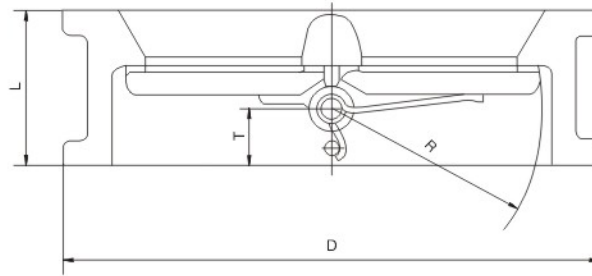

## CL150

Spec (NAP)	in	2	2 1/2	3	4	5	6	8	10	12	14	16	18	20	24	28	30	32
Face to face(mm)	L	60	67	73	73	86	98	127	146	181	184	191	203	219	222	305	305	305
Center height(mm)	H	103	122	135	173	195	220	277	337	47	448	512	547	604	715	773	824	878
Weight (Kg)		2	3	4	6	8	13	25	39	54	80	117	138	163	331	380	878	560

## CL300

Spec (NAP)	in	2	2 1/2	3	4	5	6	8	10	12	14	16	18	20	24	28	30	32
Face to face(mm)	L	60	67	73	73	86	98	127	146	181	222	232	264	292	318	-	368	-
Center height(mm)	H	110	128	147	179	214	249	305	359	420	483	537	594	652	722	-	882	-
Weight (Kg)		3	4	6	8	15	18	51	51	77	117	190	200	265	410	-	660	-

## CL600

Spec (NAP)	in	2	2 1/2	3	4	5	6	8	10	12	14	16	18	20	24	28	30	32
Face to face(mm)	L	60	67	73	79	105	136	165	213	229	273	305	362	368	438	-	-	-
Center height(mm)	H	110	128	147	191	239	264	318	398	455	490	562	610	680	786	-	-	-
Weight (Kg)		4	5	8	11	20	26	55	95	140	223	360	395	518	836	-	-	-

# Check Valve

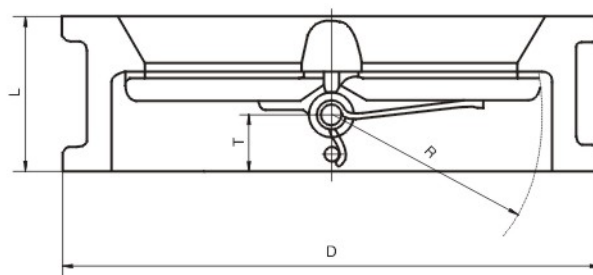

## CL900

Spec (NAP)	in	2	2 1/2	3	4	5	6	8	10	12	14	16	18	20	24	28	30	32
Face to face(mm)	L	70	83	83	102	110	159	206	241	292	356	384	451	451	495	-	-	-
Center height(mm)	H	140	162	165	204	245	286	356	432	495	518	572	635	695	835	-	-	-
Weight (Kg)		8	11	14	20	30	42	84	145	220	350	470	605	820	1050	-	-	-

## CL1500

Spec (NAP)	in	2	2 1/2	3	4	5	6	8	10	12	14	16	18	20	24	28	30	32
Face to face(mm)	L	70	83	83	102	110	159	206	248	305	356	384	-	-	-	-	-	-
Center height(mm)	H	140	162	172	207	252	280	350	433	518	576	639	-	-	-	-	-	-
Weight (Kg)		8	11	19	26	51	68	130	210	384	550	635	-	-	-	-	-	-



# Check Valve



## H74H TYPE

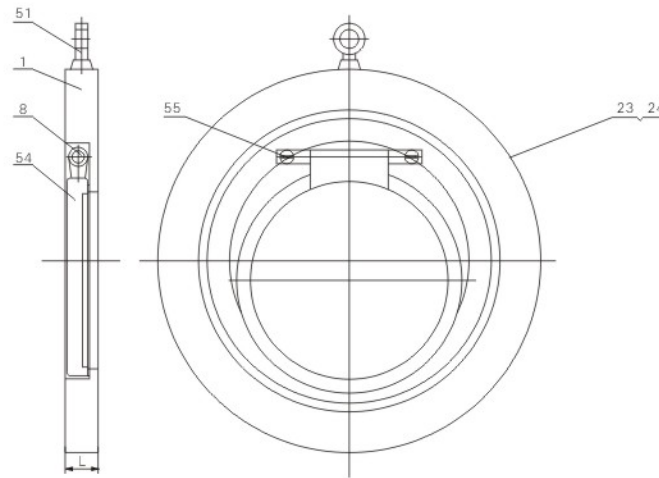

### MAIN PARTS MATERIAL SHEET

Item	Part name	WCB	CF8	CF3	CF3M	CE3MN
1	Body	A216 WCB	A351 CF8	A351 CF3	A351 CF3M	CE3MN
8	Bonnet	410	304	304L	316L	F53
23	Nameplate	304	304	304	304	304
24	Rivet	AL	AL	AL	AL	AL
51	Hanger bolt	A193 B7	A193 B7	A193 B7	A193 B7	A193 B7
54	Disc	A351 CF8	A351 CF8	A351 CF3	A351 CF3M	CE3MN
55	Dormant screw	A193 B8	A193 B8	A193 B8	A193 B8M	A193 B8M

## CL150

Spec (NAP)	in	2	2 1/2	3	4	6	8	10	12	14	16	18	20	24
Face to face(mm)	L	114	127	140	165	280	305	330	356	381	406	432	457	508
Center height(mm)	H	90	105	121	147	170	210	245	280	320	365	420	470	510

## CL300

Spec (NAP)	in	2	2 1/2	3	4	6	8	10	12	14	16	18	20	24
Face to face(mm)	L	114	127	140	165	280	305	330	356	381	406	432	457	508
Center height(mm)	H	110	120	130	147	175	220	257	305	340	385	430	475	252

# Check Valve

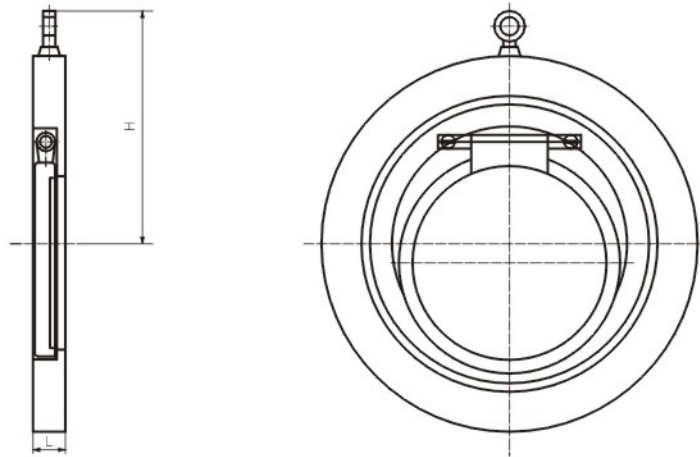

## CL600

Spec (NAP)	in	2	2 1/2	3	4	6	8	10	12	14	16	18	20	24
Face to face(mm)	L	152	170	190	229	280	318	330	356	381	406	432	457	508
Center height(mm)	H	111	128	134	147	189	234	275	3178	360	400	450	490	540

## CL1900

Spec (NAP)	in	2	2 1/2	3	4	6	8	10	12	14	16	18	20	24
Face to face(mm)	L	203	224	241	260	323	450	500	545	608	670	725	776	877
Center height(mm)	H	138	158	174	190	220	260	300	335	386	448	496	554	596

## CL1500

Spec (NAP)	in	2	2 1/2	3	4	6	8	10	12	14	16	18	20	24
Face to face(mm)	L	203	224	241	279	343	470	521	585	648	711	775	826	927
Center height(mm)	H	152	180	205	235	260	300	340	385	440	490	545	595	650

# Strainer



# Y-Strainer

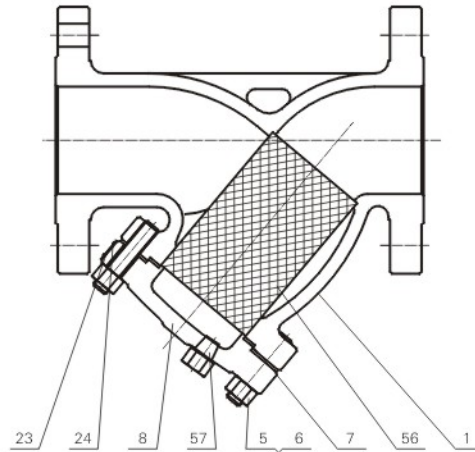

## MAIN PARTS MATERIAL SHEET

Item	Part name	WCB	CF8	CF3	CF3M	CE3MN
1	Body	A216 WCB	A351 CF8	A351 CF3	A351 CF3M	CE3MN
5	Bolt	A193 B7	A193 B8	A193 B8	A193 B8M	A193 B8M
6	Nut	A194 2H	A194 8	A194 8	A194 8M	A194 8M
7	Gasket	Graphite	Graphite	Graphite	Graphite	Graphite
8	Bonnet	A216 WCB	A351 CF8	A351 CF3	A351 CF3M	CE3MN
23	Nameplate	AISI 304	AISI 304	AISI 304	AISI 304	AISI 304
24	Rivet	AL	AL	AL	AL	AL
56	Strainer net	304	304	304	316	316
57	Waste plug	1035	304	304	316	316

Note: please give strainer net mesh when you order



# Y-Strainer

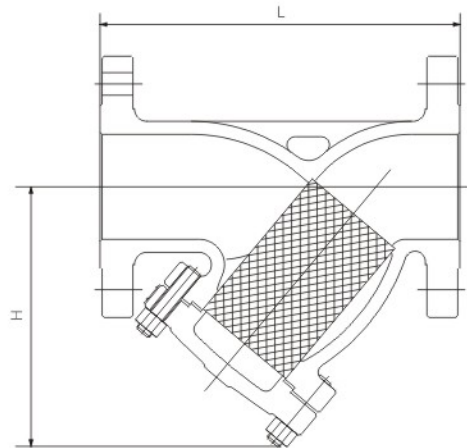

Please give strainer net mesh when you order

## CL150

Spec (NAP)	in	1/2	3/4	1	1 1/2	2	2 1/2	3	4	6	8
Face to face(mm)	L	130	150	160	200	230	290	310	350	480	600
Center height(mm)	H	70	70	95	135	165	180	189	235	345	410
Weight (Kg)		1.8	3	6	8	10	13	15	26	53	76

## CL300

Spec (NAP)	in	1/2	3/4	1	1 1/2	2	2 1/2	3	4	6	8
Face to face(mm)	L	130	150	160	200	230	290	310	350	480	600
Center height(mm)	H	70	70	95	135	165	180	189	235	345	410
Weight (Kg)		3	5	8	10	13	20	40	60	83	112

## CL600

Spec (NAP)	in	1/2	3/4	1	1 1/2	2	2 1/2	3	4	6	8
Face to face(mm)	L	160	160	175	230	250	290	310	350	480	560
Center height(mm)	H	80	80	110	150	180	195	200	255	370	430
Weight (Kg)		2.5	5	10	12	15	25	50	75	113	155

# Bellow Valve



# Bellow Gate Valve



## WZ40H TYPE

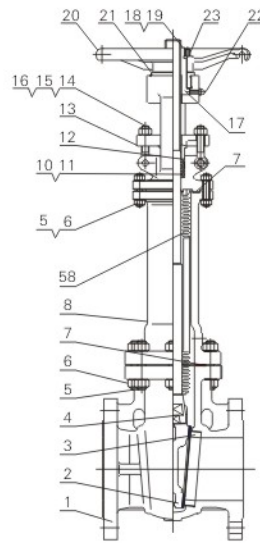

### MAIN PARTS MATERIAL SHEET

Item	Part name	WCB	CF8	CF3	CF3M	CE3MN
1	Body	A216 WCB	A351 CF8	A351 CF3	A351 CF3M	CE3MN
2	Wedge	A216 WCB	A351 CF8	A351 CF3	A351 CF3M	CE3MN
3	Seat	A105	A182 F304	A182 F304L	A182 F316L	F53
4	Stem	A182 F6a	A182 F304	A182 F304L	A182 F316L	F53
5	Bolt	A193 B7	A193 B8	A193 B8	A193 B8M	A193 B8M
6	Nut	A194 2H	A194 8	A194 8	A194 8M	A194 8M
7	Gasket	304+flexible graphite	304+flexible graphite	304+flexible graphite	316+flexible graphite	316+flexible graphite
8	Bonnet	A216 WCB	A351 CF8	A351 CF3	A351 CF3M	A351 CE3MN
10	Packing	304+flexible graphite	304+flexible graphite	304+flexible graphite	316+flexible graphite	316+flexible graphite
11	Distance ring	A182 F6a	A182 F304	A182 F304	A182 F316	F53
12	Packing gland	A182 F6a	A182 F304	A182 F304	A182 F316	F53
13	Packing plate	A216 WCB	A351 CF8	A351 CF8	A351 CF8	A351 CF8
14	Eye bolt	A193 B7	A193 B8	A193 B8	A193 B8M	A193 B8M
15	Nut	A194 2H	A194 8	A194 8	A194 8M	A194 8M
16	Pin	1035	304	304	304	304
17	Stem bolt	A439 type D2	A439 type D2	A439 type D2	A439 type D2	A439 type D2
18	Locking nut	1035	1035	1035	1035	1035
19	Locking screw	1035	1035	1035	1035	1035
20	Hand wheel	Ducerle L10m	Ducerle L10m	Ducerle L10m	Ducerle L10m	Ducerle L10m
21	Bearing gland	1035	1035	1035	1035	1035
22	Oil cup	Finished product	Finished product	Finished product	Finished product	Finished product
23	Nameplate	AL	AL	AL	AL	AL
58	Bellow	F321	F321	F321	F316L	F53

Note: the distance ring should be installed if user require

# Gate Valve



**Z40 H  
Y TYPE**

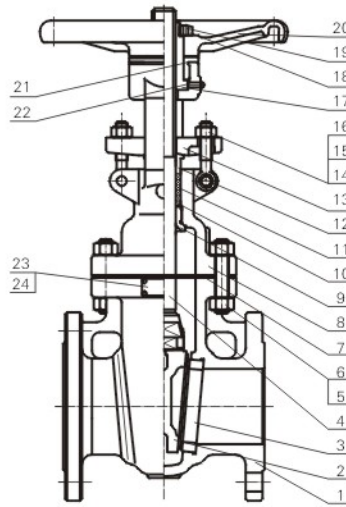

## MAIN PARTS MATERIAL SHEET

Item	Part name	WCB	C5	WC6	CF8	CF8M	
1	Body	A216 WCB	A217 C5	A217 WC6	A351 CF8	A351 CF8M	
2	Wedge disc	A216 WCB/STL.6	A217 C5/STL.6	A217 WC6/STL.6	A351 CF8	A351 CF8M	
3	Seat	A105/STL.6	A182 F11/STL.6	A182 F11/STL.6	A182 F304/STL.6	A182F 316/STL 6	
4	Stem	A182 F6a	A182 F6a	A182 F6a	A182 304	A479 316	
5	Bolt	A193 B7	A193 B7	A193 B7	A193 B8	A193 B8M	
6	Nut	A194 2H	A194 2H	A194 2H	A194 8	A194 8M	
7	Gasket 150Lb	304+flexible graphite				316+flexible graphite	
	Gasket 300Lb	304+flexible graphite				Spiral wound	
	Gasket ≥600Lb	F304				Spiral wound	
8	Bonnet	A216 WCB	A217 C5	A217 WC6	A351 CF8	A351 CF8M	
9	Backseat	A182 F6a	A182 F6a	A182 F6a	A182 F6a	A182 F316	
10	Packing	304+flexible graphite				Pillar 6610+6528	
11	Distance Ring	A182 F6a	A182 F6a	A182 F6a	A182 F304	A182 F316	
12	Packing gland	A182 F6a	A182 F6a	A182 F6a	A182 F304	A182 F316	
13	Packing plate	A216 WCB	A216 WCB	A216 WCB	A351 CF8	A351 CF8	
14	Eye bolt	A193 B7	A193 B7	A193 B7	A193 B8	A193 B8	
15	Nut	A194 2H	A194 2H	A194 2H	A194 8	A194 8	
16	Pin	1035	1035	1035	304	304	
17	Stem nut	A439 Type D2	A439 Type D2	A439 Type D2	A439 Type D2	A439 Type D2	
18	Locking nut	1035	1035	1035	1035	1035	
19	Locking screw	1035	1035	1035	1035	1035	
20	Hand wheel	AISI 1118	AISI 1118	AISI 1118	AISI 1118	AISI 1118	
21	Bearing gland	1035	1035	1035	1035	1035	
22	Oil cap	Finished product	Finished product	Finished product	Finished product	Finished product	
23	Nameplate	AISI 304	AISI 304	AISI 304	AISI 304	AISI 304	
24	Rivet	AL	AL	AL	AL	AL	

Note: the distance ring should be installed if user require

# Bellow Gate Valve

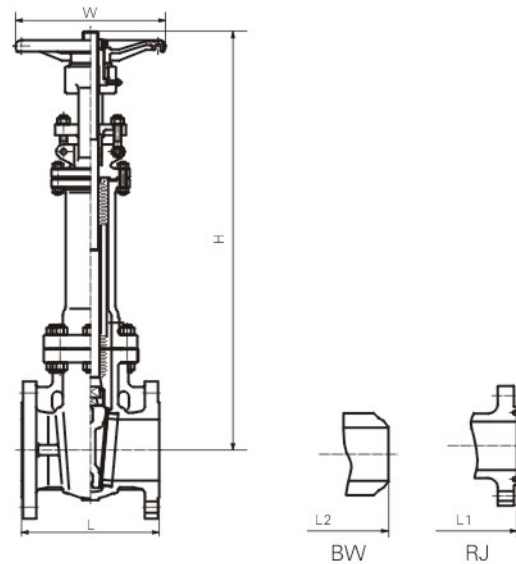

## CL150

Spec (NAP)	in	2	2 1/2	3	4	5	6	8	10	12	14	16	18	20	24
Face to face(mm)	L	178	190	203	229	254	267	292	330	356	381	406	432	457	508
	L1	191	203	216	241	267	279	305	343	368	394	419	445	470	521
	L2	216	241	283	305	381	403	419	457	502	572	610	660	711	813
Center height(mm)	H	440	520	570	690	810	920	1200	1430	1650	1920	2120	2450	2700	3200
Hand wheel diameter (mm)	W	200	200	250	280	300	300	350	400	450	500	600	680	750	800
Weight (Kg)		30	50	65	80	95	122	160	260	340	500	610	780	900	1350

## CL300

Spec (NAP)	in	2	2 1/2	3	4	5	6	8	10	12	14	16	18	20	24
Face to face(mm)	L	216	241	283	305	381	403	419	457	502	762	838	914	991	1143
	L1	232	257	298	321	397	419	435	473	518	778	854	930	1010	1165
	L2	216	241	283	305	381	403	419	457	502	762	838	914	991	1143
Center height(mm)	H	450	560	590	730	850	960	1250	1500	1720	2010	2250	2620	2900	3360
Hand wheel diameter (mm)	W	200	200	250	300	300	350	400	450	500	550	680	750	920	-
Weight (Kg)		35	55	70	85	100	125	175	290	365	540	650	820	930	1400

## CL600

Spec (NAP)	in		2 1/2	3	4	5	6	8	10	12	14	16	18	20	24
Face to face(mm)	L	292	330	356	432	508	559	660	787	838	889	991	1092	1194	1397
	L1	295	333	359	435	511	562	664	791	841	892	994	1095	1200	1407
	L2	292	330	356	432	508	559	660	787	838	889	991	1092	1194	1397
Center height(mm)	H	465	585	600	750	870	980	1270	1525	1750	2140	2270	2650	2930	3390
Hand wheel diameter (mm)	W	200	250	280	300	400	450	500	680	750	700	-	-	-	-
Weight (Kg)		45	65	80	95	125	135	185	310	395	575	690	850	970	1460

# Bellow Globe Valve



## WJ41H TYPE

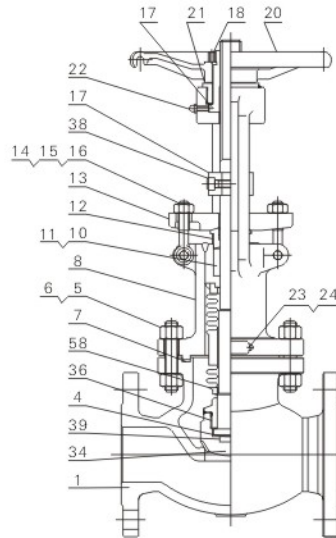

### MAIN PARTS MATERIAL SHEET

Item	Part name	WCB	CF8	CF3	CF3M	CE3MN
1	Body	A216 WCB	A351 CF8	A351 CF3	A351 CF3M	CE3MN
4	Stem	A182 F6a	A182 304	A182 F304L	A351 F316L	A182 F53
5	Bolt	A193 B7	A193 B8	A193 B8	A193 B8M	A193 B8M
6	Nut	A194 2H	A194 8	A194 8	A194 8M	A194 8M
7	Gasket	304+flexible graphite	304+flexible graphite	304+flexible graphite	316+flexible graphite	316+flexible graphite
8	Bonnet	A216 WCB	A351 CF8	A351 CF3	A351 CF3M	CE3MN
10	Packing	304+flexible graphite	304+flexible graphite	304+flexible graphite	316+flexible graphite	316+flexible graphite
11	Distance ring	A182 F6a	A182 F304	A182 F304L	A182 F316L	A182 F53
12	Packing gland	A182 F6a	A182 F304	A182 F304L	A182 F316L	A182 F53
13	Packing plate	A216 WCB	A351 CF8	A351 CF8	A351 CF8	A351 CF8
14	Eye bolt	A193 B7	A193 B8	A193 B8	A193 B8M	A193 B8M
15	Nut	A194 2H	A194 8	A194 8	A194 8M	A194 8M
16	Pin	1035	304	304	304	304
17	Stem bolt	A439 type D2	A439 type D2	A439 type D2	A439 type D2	A439 type D2
18	Locking nut	1035	1035	1035	1035	1035
20	Hand wheel	Dulerle L10m	Dulerle L10m	Ducerle L10m	Ducerle L10m	Ducerle L10m
21	Bearing gland	1035	1035	1035	1035	1035
22	Oil cup	Finished product	Finished product	Finished product	Finished product	Finished product
23	Nameplate	304	304	304	304	304
24	Rivet	AL	AL	AL	AL	AL
34	Disc	A105	F304	F304L	F316L	F51
36	Disc cover	1035	304	304L	316L	F53
37	Guide pad	1045	1045	1045	1045	1045
38	Hex. Bolt	A193 B7	A193 B7	A193 B7	A193 B7	A193 B7
39	Washer	420	304	304L	316L	F53
58	Bellow	F321	F321	F304L	F316L	F53

Note: the distance ring should be installed if user require

# Bellow Globe Valve

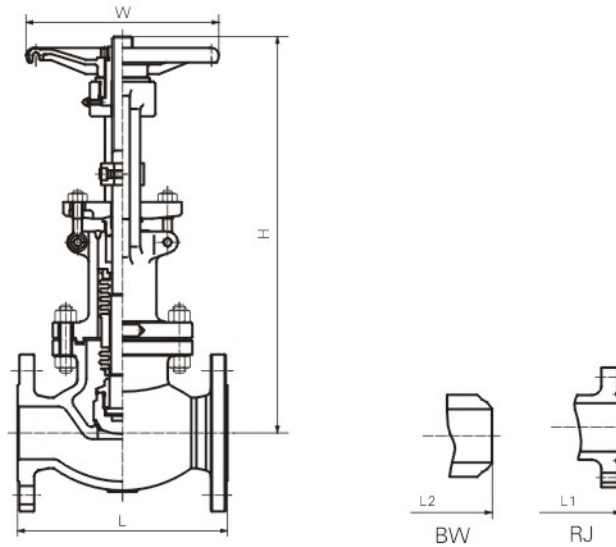

## CL150

Spec (NAP)	in	2	2 1/2	3	4	5	6	8	10	12	14	16
Face to face(mm)	L	203	216	241	292	356	406	495	622	698	787	914
	L1	216	229	254	305	369	419	508	635	711	800	927
	L2	203	216	241	292	356	406	495	622	698	787	914
Center height(mm)	H	455	520	570	710	790	860	1250	1460	1540	1800	2100
Hand wheel diameter (mm)	W	220	250	280	320	320	400	450	560	560	-	-

## CL300

Spec (NAP)	in	2	2 1/2	3	4	5	6	8	10	12	14	16
Face to face(mm)	L	267	292	318	356	400	445	559	622	711	838	863
	L1	283	308	334	372	416	461	575	638	727		
	L2	267	292	318	356	400	445	559	622	711		
Center height(mm)	H	500	550	620	790	860	950	1400	1500	1700		
Hand wheel diameter (mm)	W	220	350	280	320	400	450	500	560	600		

## CL600

Spec (NAP)	in	2	2 1/2	3	4	5	6	8	10	12	14	16
Face to face(mm)	L	292	330	356	432	508	559	660	787	838		
	L1	295	333	359	435	511	562	663	790	841		
	L2	292	330	356	432	508	559	660	787	838		
Center height(mm)	H	550	610	680	820	900	1050	1540	1620	1800		
Hand wheel diameter (mm)	W	285	280	320	400	-	560	600	650	760		

# Cryogenic Valve





# Cryogenic Gate Valve



## DZ41Y TYPE

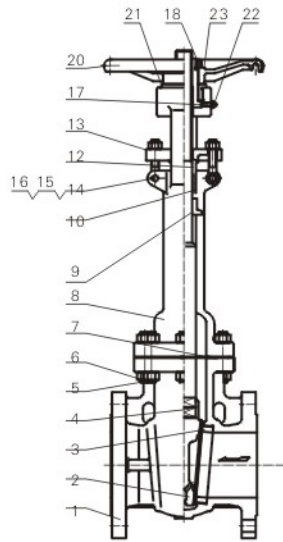

### MAIN PARTS MATERIAL SHEET

Item	Part name	LC3	CF8	CF3	CF3M	CE3MN
1	Body	A352 LC3	A351 CF8	A351 CF3	A351 CF3M	CE3MN
2	Wedge disc	A352 LC3	A351 CF8	A351 CF3	A351 CF3M	CE3MN
3	Seat	A352 LC3	F304	F304L	F316L	F53
4	Stem	A182 F304	F304	A182 F304L	A182 F316L	A182 F53
5	Bolt	A193 B16	A182 B8	A193 B8	A193 B8M	A193 B8M
6	Nut	A194 4	A194 8	A194 8	A194 8M	A194 8M
7	Gasket	304+flexible graphite	304+flexible graphite	304+flexible graphite	316+flexible graphite	316+flexible graphite
8	Bonnet	A352 LC3	A351 CF8	A351 CF3	A351 CF3M	CE3MN
9	Packing	A182 F304	F304	F304L	F316C	F53
10	Distance Ring	304+flexible graphite	304+flexible graphite	304+flexible graphite	316+flexible graphite	316+flexible graphite
12	Packing gland	A182 F304	F304	F304	A182 F316L	A182 F316L
13	Packing plate	A216 WCB	CF8	CF8	A351 CF8	A351 CF8
14	Eye bolt	A193 B16	B8	B8	A193 B8M	A193 B8M
15	Nut	A194 4	8	8	A194 8M	A194 8M
16	Pin	1035	304	304	304	304
17	Stem nut	A439 type D2	A439 type D2	A439 type D2	A439 type D2	A439 type D2
18	Locking nut	1035	1035	1035	1035	1035
20	Hand wheel	Ducerle L10m	DucerleL10m	Ducerle L10m	Ducerle L10m	Ducerle L10m
21	Bearing gland	1035	1035	1035	1035	1035
22	Oil cap	Finished product	Finished product	Finished product	Finished product	Finished product
23	Nameplate	304	304	304	304	304

# Cryogenic Gate Valve

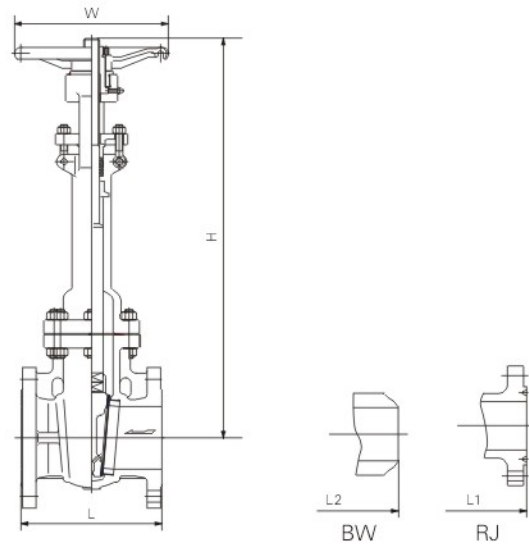

## CL150

Spec (NAP)	in	2	2 1/2	3	4	5	6	8	10	12	14	16	18	20	24	28	30	32	36
Face to face(mm)	L	178	190	203	229	254	267	292	330	356	381	406	432	457	508	610	610	660	711
	L1	191	203	216	241	267	279	305	343	368	394	419	445	470	521	-	-	-	-
	L2	216	241	283	305	381	403	419	457	502	572	610	660	711	813	914	914	956	1060
Center height(mm)	H	510	550	590	670	750	800	890	1150	1285	1420	1550	1690	1840	2140	2300	2600	2830	3100
Hand wheel diameter (mm)	W	200	200	250	280	300	300	350	400	450	500	600	680	750	800				

## CL300

Spec (NAP)	in	2	2 1/2	3	4	5	6	8	10	12	14	16	18	20	24	28	30	32	36
Face to face(mm)	L	216	241	283	305	381	403	419	457	502	762	838	914	991	1143	1346	1397	1524	1727
	L1	232	257	298	321	397	419	435	473	518	778	854	930	1010	1165	1372	1422	1553	1756
	L2	216	241	283	305	381	403	419	457	502	762	838	914	991	1143	1346	1397	1524	1727
Center height(mm)	H	515	565	615	690	770	820	915	1175	1305	1450	1580	1720	1860	2170	2340	2640	2870	3150
Hand wheel diameter (mm)	W	200	200	250	300	300	350	400	450	500	550	680	750	920	-	-	-	-	-

## CL600

Spec (NAP)	in	2	2 1/2	3	4	5	6	8	10	12	14	16	18	20	24	28	30	32	36
Face to face(mm)	L	292	330	356	432	508	559	660	787	838	889	991	1092	1194	1397				
	L1	295	333	359	435	511	562	664	791	841	892	994	1095	1200	1407				
	L2	292	330	356	432	508	559	660	787	838	889	991	1092	1194	1397				
Center height(mm)	H	540	595	640	730	810	865	950	1205	1345	1500	1640	1760	1960	2210				
Hand wheel diameter (mm)	W	200	250	280	300	400	450	500	680	750	700	-	-	-	-				

# Cryogenic Gate Valve

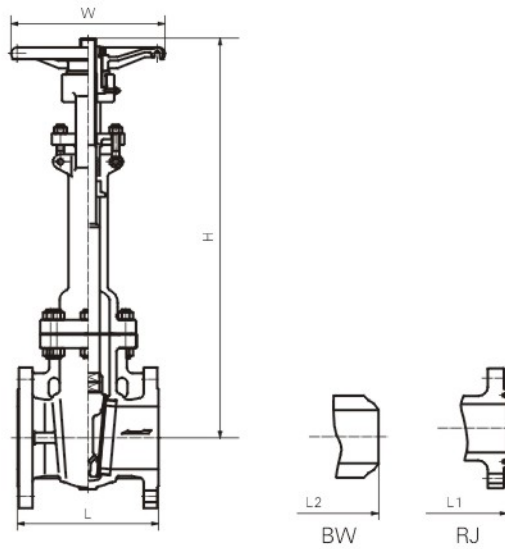

## CL900

Spec (NAP)	in	2	2 1/2	3	4	5	6	8	10	12	14	16	18	20	24	
Face to face(mm)	L	368	419	381	457	559	610	737	838	965	1029	1130				
	L1	371	422	384	460	562	613	740	841	968	1039	1140				
	L2	368	419	381	457	559	610	737	838	965	1029	1130				
Center height(mm)	H	605	640	700	760	850	905	1000	1255	1400	1590	1710				
Hand wheel diameter (mm)	W	300	300	350	400	-	600	600	650	700	-	-				

## CL1500

Spec (NAP)	in	2	2 1/2	3	4	5	6	8	10	12	14	16	18	20	24	
Face to face(mm)	L	368	419	470	546	673	705	832	991	1130	1257	1384				
	L1	371	422	473	549	676	711	842	1001	1146	1276	1406				
	L2	368	419	470	546	673	705	832	911	1130	1257	1384				
Center height(mm)	H	625	680	750	800	900	960	1060	1300	1505	1700	1800				
Hand wheel diameter (mm)	W	300	350	400	550	-	-	-	-	-	-	-				

# Cryogenic Globe Valve



## DJ41Y TYPE

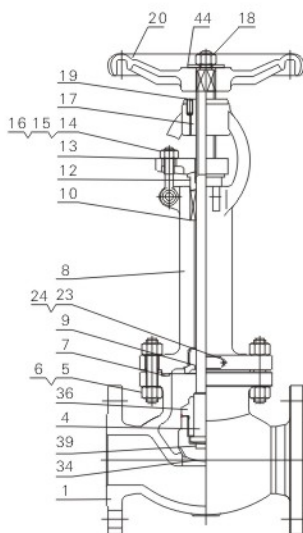

### MAIN PARTS MATERIAL SHEET

Item	Part name	LC3	CF8	CF3	CF3M	CE3MN
1	Body	A352 LC3	A351 CF8	A351 CF3	A351 CF3M	CE3MN
4	Stem	A182 F304	A182 F304	A182 F304L	A182 F316L	A182 F53
5	Bolt	A193 B7	A193 B8	A193 B8	A193 B8M	A193 B8M
6	Nut	A194 2H	A194 8	A194 8	A194 8M	A194 8M
7	Bonnet	304+柔性石墨	304+柔性石墨	304+柔性石墨	316+柔性石墨	316+柔性石墨
8	Packing	A352 LC3	A351 CF8	A351 CF3	A351 CF3M	CE3MN
9	Distance ring	A182 F304	A182 F304	A182 F304L	A182 F316L	A182 FF53
10	Packing gland	304+柔性石墨	304+柔性石墨	304+柔性石墨	316+柔性石墨	316+柔性石墨
12	Packing plate	A182 F304	A182 F304	A182 F304L	A182 F316L	A182 F53
13	Eye bolt	A216 WCB	A351 CF8	A351 CF8	A351 CF8	A351 CF8
14	Nut	A193 B7	A193 B8	A193 B8	A193 B8M	A193 B8M
15	Pin	A194 2H	A194 8	A194 8	A194 8M	A194 8M
16	Stem nut	420	304	304	304	304
17	Locking nut	A439 type D2	A439 type D2	A439 type D2	A439 type D2	A439 type D2
18	Locking screw	1035	1035	1035	1035	1035
19	Hand wheel	1035	1035	1035	1035	1035
20	Nameplate	Ducerle L10m	Ducerle L10m	Ducerle L10m	Ducerle L10m	Ducerle L10m
23	Rivet	304	304	304	304	304
24	Pressure seal seat	AL	AL	AL	AL	AL
34	Disc	F304	F304	F304L	F316L	F53
36	Disc cover	F304	F304	F304L	F316L	F53
39	Gasket	304	304	304	316	F53
44	Washer	1035	1035	1035	1035	1035

# Cryogenic<sup>®</sup> Globe Valve

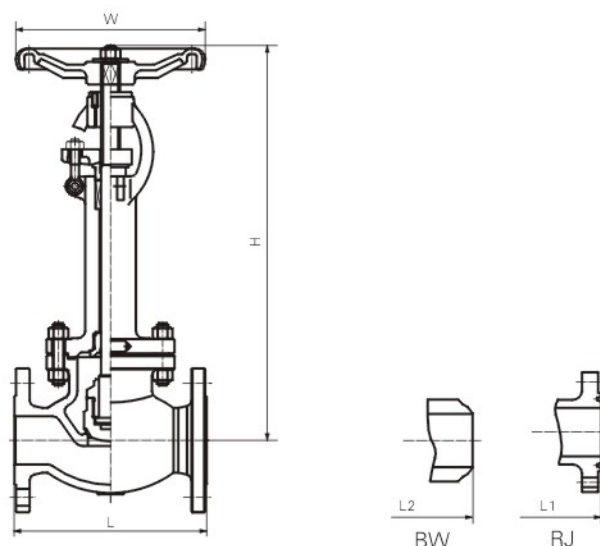

## CL150

Spec (NAP)	in	2	2 1/2	3	4	5	6	8	10	12	14	16
Face to face(mm)	L	203	216	241	292	356	406	495	622	698	787	914
	L1	216	229	254	305	369	419	508	635	711	800	927
	L2	203	216	241	292	356	406	495	622	698	787	914
Center height(mm)	H	520	540	575	640	675	757	927	1028	1060	1200	1305
Hand wheel diameter (mm)	W	220	250	280	320	320	400	450	560	560	-	-

## CL300

Spec (NAP)	in	2	2 1/2	3	4	5	6	8	10	12	14	16
Face to face(mm)	L	267	292	318	356	400	445	559	622	711	838	863
	L1	283	308	334	372	416	461	575	638	727		
	L2	267	292	318	356	400	445	559	622	711		
Center height(mm)	H	530	560	595	660	705	770	950	1060	1105		
Hand wheel diameter (mm)	W	220	350	280	320	400	450	500	560	600		

## CL600

Spec (NAP)	in	2	2 1/2	3	4	5	6	8	10	12	14	16
Face to face(mm)	L	292	330	356	432	508	559	660	787	838		
	L1	295	333	359	435	511	562	663	790	841		
	L2	292	330	356	432	508	559	660	787	838		
Center height(mm)	H	560	600	625	690	730	805	995	1100	1195		
Hand wheel diameter (mm)	W	285	280	320	400	500	560	600	650	760		

# Special Features

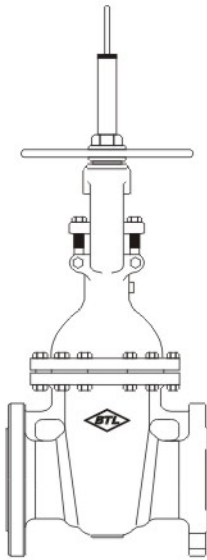

Lift indicator

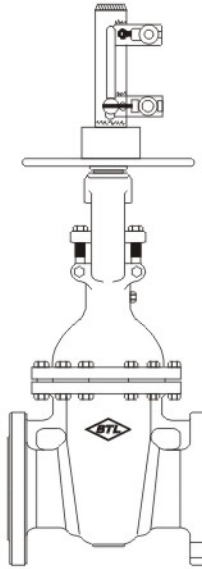

Limit micro switches

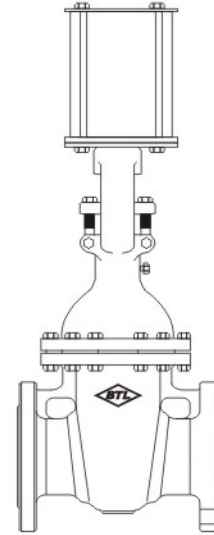

Pneumatic operator

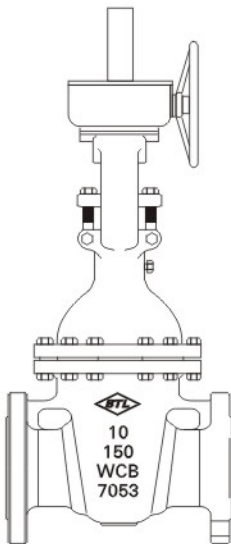

Bevel gearing

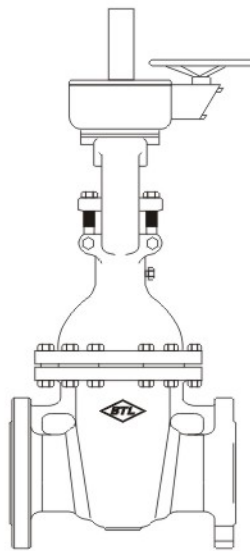

Bevel gearing with horizontal handwheel

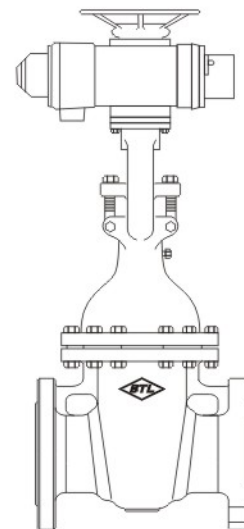

Electric actuator

# Gate Valves

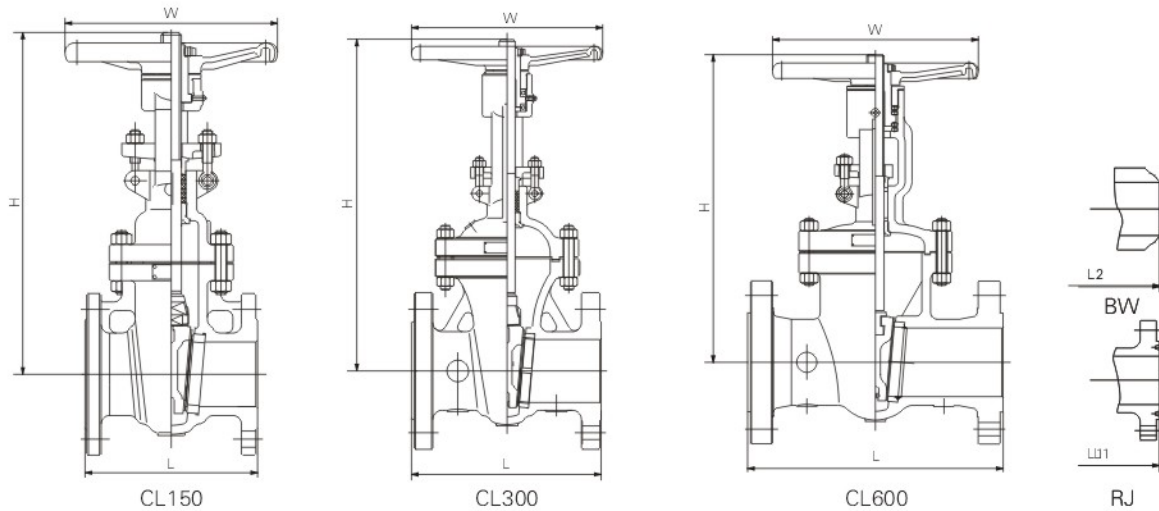

## CL150

Spec (NPS)	in	2	2 1/2	3	4	5	6	8	10	12	14	16	18	20	24	28	30	32	36	40	42	48	60	
L		178	190	203	229	254	267	292	330	356	381	406	432	457	508	610	610	660	711	762	787	914	1067	
Face to face(mm)	L1	191	203	216	241	267	279	305	343	368	394	419	445	470	521	-	-	-	-	-	-	-	-	-
	L2	216	241	283	305	381	403	419	457	502	572	610	660	711	813	914	914	965	1060	1067	1118	-	-	-
Center height(mm)	H	341	371	402	472	530	587	743	904	1047	1172	1297	1433	1590	1898	2050	2330	2533	2800	-	-	-	-	-
Hand wheel diameter(mm)	W	200	200	250	280	300	300	350	400	450	500	600	680	750	800	-	-	-	-	-	-	-	-	-
Weight (Kg)		20	30	33	49	60	75	120	205	290	400	511	650	789	1200	1800	2560	3060	3500	-	-	-	-	-

## CL300

Spec (NPS)	in	2	2 1/2	3	4	5	6	8	10	12	14	16	18	20	24	28	30	32	36
L		216	241	283	305	381	403	419	457	502	762	838	914	991	1143	1346	1397	1524	1727
Face to face(mm)	L1	232	257	298	321	397	419	435	473	518	778	854	930	1010	1165	1371	1422	1552	1755
	L2	216	241	283	305	381	403	419	457	502	762	838	914	991	1143	1346	1397	1524	1727
Center height(mm)	H	345	376	407	478	535	618	765	929	1094	1188	1329	1455	1860	2030	-	-	-	-
Hand wheel diameter(mm)	W	200	200	250	300	300	350	400	450	500	550	680	750	920	-	-	-	-	-
Weight (Kg)		24	36	47	69	89	123	196	333	440	710	950	1405	1720	2770	3312	4100	5200	6700

## CL600

Spec (NPS)	in	2	2 1/2	3	4	5	6	8	10	12	14	16	18	20	24	28	30	32	36
L		292	330	356	432	508	559	660	787	838	889	991	1092	1194	1397	1549	1651	1778	2083
Face to face(mm)	L1	295	333	359	435	511	562	664	791	841	892	994	1095	1200	1407	1562	1664	1794	2096
	L2	292	330	356	432	508	559	660	787	838	889	991	1092	1194	1397	1549	1651	1778	2083
Center height(mm)	H	377	443	465	525	610	672	820	983	1120	1283	1429	1572	1757	1985	2230	2475	2300	2950
Hand wheel diameter(mm)	W	200	250	280	300	400	450	500	680	750	700	-	-	-	-	-	-	-	-
Weight (Kg)		39	52	88	114	-	285	413	650	800	1140	1700	2268	2850	3500	-	-	-	-

# Special features

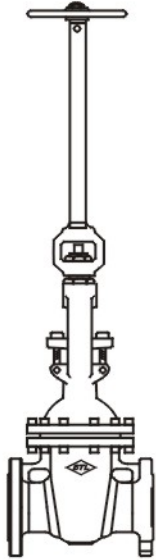

Extension stem

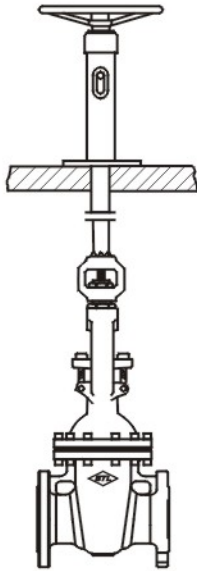

Floor stand

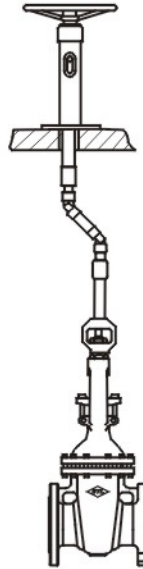

Floor stand with universal joint

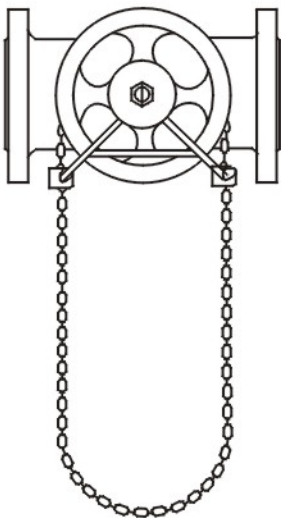

Chain wheel

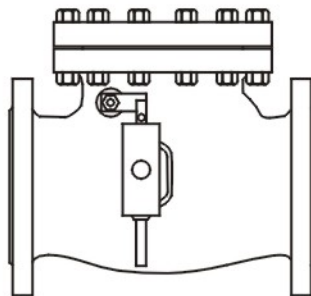

Check valve with dash pot

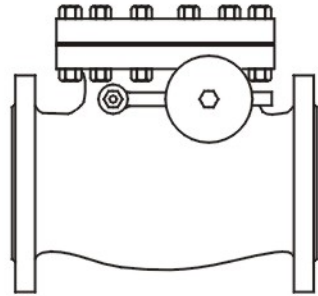

Check valve with Outside lever & weight



# Material Performance Sheet



ASTM Code	Chemical analyze											Mechanical property				硬度	冲击值
	C	Mn	P	S	Si	Cr	Mo	Ni	Cu	V	Nb	Tensile MPa, ≥	Yield MPa, ≥	Elongation %, ≥	Reduce %, ≥	Brinell HB, ≤	J, ≥
A105	0.35	0.60~1.05	0.035	0.040	0.10~0.35	0.30	0.12	0.4	0.40	0.08	0.02	485	250	30	30	187	
A182F11	0.05~0.15	0.30~0.60	0.030	0.030	0.50~1.00	1.00~1.50	0.44~0.65					415	205	20	45	121~174	
A182F22	0.05~0.15	0.30~0.60	0.040	0.040	0.50	2.00~2.50	0.87~1.13					415	205	20	35	170	
A182F304	0.08	2.00	0.045	0.030	1.00	18.0~20.0		8.0~11.0				515	205	30	50		
A182F304L	0.030	2.00	0.045	0.030	1.00	18.0~20.0		8.0~13.0				485	170	30	50		
A182F316	0.08	2.00	0.045	0.030	1.00	16.0~18.0	2.00~3.00	10.0~14.0				515	205	30	50		
A182F316L	0.030	2.00	0.045	0.030	1.00	16.0~18.0	2.00~3.00	10.0~15.0				485	170	30	50		
A182F51	0.030	2.00	0.030	0.020	1.00	21.0~23.0	2.5~3.5	4.5~6.5				620	450	25	45		
A182F6a	0.15	1.00	0.040	0.030	1.00	11.5~13.5		0.50				585	380	18	35	167~229	
A193B7	0.37~0.49	0.65~1.10	0.035	0.040	0.15~0.35	0.75~1.20	0.15~0.25					860	720	16	50	321	
A193B7M	0.37~0.49	0.65~1.10	0.035	0.040	0.15~0.35	0.75~1.20	0.15~0.25	8.0~11.0				690	550	18	50	235	
A193B8	0.08	2.00	0.045	0.030	1.00	18.0~20.0		10.0~14.0		0.25~0.35		515	205	30	50	223	
A193B8M	0.08	2.00	0.045	0.030	1.00	16.0~18.0	2.00~3.00					515	205	30	50	223	
A193B16	0.36~0.47	0.45~0.70	0.035	0.040	0.15~0.35	0.80~1.15	0.50~0.65					860	720	18	50	321	
A1942H	≥0.40	1.00	0.040	0.050	0.04											248~352	
A1942HM	≥0.40	1.00	0.040	0.050	0.04			8.0~11.0								159~237	
A1948	0.08	2.00	0.045	0.030	1.00	18.0~20.0		10.0~14.0								126~300	
A1948M	0.08	2.00	0.045	0.030	1.00	16.0~18.0	2.00~3.00									126~300	
A216WCB	0.30	1.00	0.04	0.045	0.60	0.50	0.20	0.50	0.30	0.03		485~655	250	22	35		
A216WCC	0.25	1.20	0.04	0.045	0.60	0.50	0.2	0.50	0.30	0.03		485~655	275	22	35		
A217C5	0.20	0.40~0.70	0.04	0.045	0.75	4.00~6.50	0.45~0.65	0.50	0.50			620~795	415	18	35		
A217CA15	0.15	1.00	0.040	0.040	1.50	11.5~14.0	0.50	1.00				620~795	450	18	30		
A217WC6	0.05~0.20	0.50~0.80	0.04	0.045	0.60	1.00~1.50	0.45~0.65	0.50	0.50			485~655	275	20	35		
A217WC9	0.05~0.18	0.40~0.70	0.04	0.045	0.60	2.00~2.75	0.90~1.20		0.50			485~655	275	20	35		
A276410	0.08~0.15	1.00	0.040	0.030	1.00	11.5~13.5						480	275	20	45		
A276420	≥0.15	1.00	0.040	0.030	1.00	12.0~14.0											
A320L7	0.38~0.048	0.75~1.00	0.035	0.040	0.15~0.35	0.80~1.10	0.15~0.25					860	725	16	50	241	Avg:27; min:20
A320L7M	0.38~0.048	0.75~1.00	0.035	0.040	0.15~0.35	0.80~1.10	0.15~0.25					690	550	18	50	235	Avg:27; min:20
A336F22	0.05~0.15	0.30~0.60	0.025	0.025	0.50	2.00~2.50	0.90~1.10					515~690	310	19	40		
A350LF1	0.30	0.60~1.35	0.035	0.040	0.15~0.30	0.30	0.12	0.40	0.40	0.08		415~585	205	28	38		Avg:18; min:14
A350LF2	0.30	0.60~1.35	0.035	0.040	0.15~0.30	0.30	0.12	0.40	0.40	0.08	0.02	485~655	250	30	30		Avg:20; min:16
A351CF3	0.03	1.50	0.040	0.040	2.00	17.0~21.0	0.50	8.0~12.0				485	205	35.0			
A351CF3M	0.03	1.50	0.040	0.040	1.50	17.0~21.0	2.0~3.00	9.0~13.0				485	205	30.0			
A351CF8	0.08	1.50	0.040	0.040	2.00	18.0~21.0	0.50	8.0~11.0				485	205	35.0			
A351CF8M	0.08	1.50	0.040	0.040	1.50	18.0~21.0	2.0~3.00	9.0~12.0				485	205	30.0			
A351CF8C	0.08	1.50	0.040	0.040	2.00	18.0~21.0	0.50	9.0~12.0	3.0~4.0			485	205	30.0			
A351CN7M	0.07	1.50	0.040	0.040	1.50	19.0~22.0	2.0~3.00	27.5~30.5				425	170	35			
A352LC1	0.25	0.50~0.80	0.04	0.045	0.60		0.45~0.65					450~620	240	24	35		
A352LC2	0.25	0.50~0.80	0.04	0.045	0.60			2.00~3.00				485~655	275	24	35		Avg:18; min:14
A352LC3	0.15	0.50~0.80	0.04	0.045	0.60			3.00~4.00				485~655	275	24	35		Avg:20; min:16
A352LCB	0.30	1.00	0.04	0.045	0.60	0.50	0.20	0.50	0.30	0.03		450~620	240	24	35		Avg:20; min:16
A352LCC	0.25	1.20	0.04	0.045	0.60	0.50	0.20	0.50		0.03		485~655	275	22	35	139~202	Avg:18; min:14
A439D2	3.00	0.70~1.25	0.08		1.50~3.00	1.75~2.75		18.00~22.00				400	207	8.0			Avg:20; min:16

# Pressure Temperature Rate



## Class 150Lb/300Lb/600Lb/900Lb/1500Lb/2500Lb Pressure Temperature Rate PSI (Psig)

Fahrenheit temperature	A216 WCB(a)						A352 LCB(d)					
	150Lb	300Lb	600Lb	900Lb	1500Lb	2500Lb	150Lb	300Lb	600Lb	900Lb	1500Lb	2500Lb
-20 to 100	285	740	1480	2220	3705	6170	265	695	1390	2085	3470	5785
200	260	675	1350	2025	3375	5625	250	655	1315	1970	3280	5470
300	230	655	1315	1970	3280	5470	230	640	1275	1915	3190	5315
400	200	635	1270	1900	3170	5280	200	620	1235	1850	3085	5145
500	170	600	1200	1975	2995	4990	170	585	1165	1745	2910	4850
600	140	550	1095	1640	2735	4560	140	535	1065	1600	2665	4440
650	125	535	1075	1610	2685	4475	125	525	1045	1570	2615	4355
700	110	535	1065	1600	2665	4440	110	520	1035	1555	2590	4320
750	95	505	1010	1510	2520	4200	95	475	945	1420	2365	3945
800	80	410	825	1235	2060	3430	80	390	780	1175	1955	3260
850	65	270	535	805	1340	2230	65	270	535	805	1340	2230
900	50	170	345	515	860	1430	50	170	345	515	860	1430
950	35	105	205	310	515	860	35	105	205	310	515	860
1000	20	50	105	155	260	430	20	50	105	155	260	430
1050	-	-	-	-	-	-	-	-	-	-	-	-
1100	-	-	-	-	-	-	-	-	-	-	-	-
1150	-	-	-	-	-	-	-	-	-	-	-	-
1200	-	-	-	-	-	-	-	-	-	-	-	-
1250	-	-	-	-	-	-	-	-	-	-	-	-
1300	-	-	-	-	-	-	-	-	-	-	-	-
1350	-	-	-	-	-	-	-	-	-	-	-	-
1400	-	-	-	-	-	-	-	-	-	-	-	-
1450	-	-	-	-	-	-	-	-	-	-	-	-
1500	-	-	-	-	-	-	-	-	-	-	-	-

## Class 150Lb/300Lb/600Lb/900Lb/1500Lb/2500Lb Pressure Temperature Rate PSI (Psig)

Fahrenheit temperature	A216 WCC(a), A352 LC2(d) A352 LC3(d), A352 LCC(e)						A217 WC1(b) A352 LC1(d)					
	150Lb	300Lb	600Lb	900Lb	1500Lb	2500Lb	150Lb	300Lb	600Lb	900Lb	1500Lb	2500Lb
-20 to 100	290	750	1500	2250	3750	6250	265	695	1390	2085	3470	5785
200	260	750	1500	2250	3750	6250	260	680	1360	2035	3395	5660
300	230	730	1455	2185	3640	6070	230	655	1305	1955	3260	5435
400	200	705	1410	2115	3530	5880	200	640	1280	1920	3200	5330
500	170	665	1330	1995	3325	5540	170	620	1245	1865	3105	5180
600	140	605	1210	1815	3025	5040	140	605	1210	1815	3025	5040
650	125	590	1175	1765	2940	4905	125	590	1175	1765	2940	4905
700	110	570	1135	1705	2840	4730	110	570	1135	1705	2840	4730
750	95	505	1010	1510	2520	4200	95	530	1065	1595	2660	4430
800	80	410	825	1235	2060	3430	80	510	1015	1525	2540	4230
850	65	270	535	805	1340	2230	65	485	975	1460	2435	4060
900	50	170	345	515	860	1430	50	450	900	1350	2245	3745
950	35	105	205	310	515	860	35	280	560	845	1405	2345
1000	20	50	105	155	260	430	20	165	330	495	825	1370
1050	-	-	-	-	-	-	-	-	-	-	-	-
1100	-	-	-	-	-	-	-	-	-	-	-	-
1150	-	-	-	-	-	-	-	-	-	-	-	-
1200	-	-	-	-	-	-	-	-	-	-	-	-
1250	-	-	-	-	-	-	-	-	-	-	-	-
1300	-	-	-	-	-	-	-	-	-	-	-	-
1350	-	-	-	-	-	-	-	-	-	-	-	-
1400	-	-	-	-	-	-	-	-	-	-	-	-
1450	-	-	-	-	-	-	-	-	-	-	-	-
1500	-	-	-	-	-	-	-	-	-	-	-	-

# Pressure Temperature Rate



## CLASS 150Lb/300Lb/600Lb/900Lb/1500Lb/2500Lb PRESSURE TEMPERATURE RATE PSI (PSIG)

Fahrenheit temperature	A217 WC4(h) A217 WC5(i)						A217 WC6(j)					
	150Lb	300Lb	600Lb	900Lb	1500Lb	2500Lb	150Lb	300Lb	600Lb	900Lb	1500Lb	2500Lb
-20 to 100	290	750	1500	2250	3750	6250	290	750	1500	2250	3750	6250
200	260	750	1500	2250	3750	6250	260	710	1425	2135	3560	5930
300	230	730	1455	2185	3640	6070	230	675	1345	2020	3365	5605
400	200	705	1410	2115	3530	5880	200	660	1315	1975	3290	5485
500	170	665	1330	1995	3325	5540	170	640	1285	1925	3210	5350
600	140	605	1210	1815	3025	5040	140	605	1210	1815	3025	5040
650	125	590	1175	1765	2940	4905	125	590	1175	1765	2940	4905
700	110	570	1135	1705	2840	4730	110	570	1135	1705	2840	4730
750	95	530	1065	1595	2660	4430	95	530	1065	1595	2660	4430
800	80	510	1015	1525	2540	4230	80	510	1015	1525	2540	4230
850	65	485	975	1460	2435	4060	65	485	975	1460	2435	4060
900	50	450	900	1350	2245	3745	50	450	900	1350	2245	3745
950	35	345	685	1030	1715	2860	35	380	755	1130	1885	3145
1000	20	215	425	640	1065	1770	20	225	445	670	1115	1860
1050	20(1)	190	380	565	945	1570	20(1)	140	275	410	684	1145
1100	-	-	-	-	-	-	20(1)	95	190	290	480	800
1150	-	-	-	-	-	-	20(1)	50	105	155	260	430
1200	-	-	-	-	-	-	15(1)	35	70	105	170	285
1250	-	-	-	-	-	-	-	-	-	-	-	-
1300	-	-	-	-	-	-	-	-	-	-	-	-
1350	-	-	-	-	-	-	-	-	-	-	-	-
1400	-	-	-	-	-	-	-	-	-	-	-	-
1450	-	-	-	-	-	-	-	-	-	-	-	-
1500	-	-	-	-	-	-	-	-	-	-	-	-

## CLASS 150Lb/300Lb/600Lb/900Lb/1500Lb/2500Lb PRESSURE TEMPERATURE RATE PSI (PSIG)

Fahrenheit temperature	A217 WC9						A217 C5					
	150Lb	300Lb	600Lb	900Lb	1500Lb	2500Lb	150Lb	300Lb	600Lb	900Lb	1500Lb	2500Lb
-20 to 100	290	750	1500	2250	3750	6250	290	750	1500	2250	3750	6250
200	260	715	1430	2150	3580	5965	260	750	1500	2250	3750	6250
300	230	675	1355	2030	3385	5640	230	730	1455	2185	3640	6070
400	200	650	1295	1945	3240	5400	200	705	1410	2115	3530	5880
500	170	640	1280	1920	3200	5330	170	665	1330	1995	3325	5540
600	140	605	1210	1815	3025	5040	140	605	1210	1815	3025	5040
650	125	590	1175	1765	2940	4905	125	590	1175	1765	2940	4905
700	110	570	1135	1705	2840	4730	110	570	1135	1705	2840	4730
750	95	530	1065	1595	2660	4430	95	530	1065	1595	2660	4430
800	80	510	1015	1525	2540	4230	80	500	995	1490	2485	4145
850	65	485	975	1460	2435	4060	65	440	880	1315	2195	3660
900	50	450	900	1350	2245	3745	50	355	705	1060	1765	2945
950	35	380	755	1130	1885	3145	35	260	520	780	1305	2170
1000	20	270	535	805	1340	2230	20	190	385	575	960	1600
1050	20(1)	200	400	595	995	1660	20(1)	140	280	420	705	1170
1100	20(1)	115	225	340	565	945	20(1)	105	205	310	515	860
1150	20(1)	105	205	310	515	860	20(1)	70	140	205	345	570
1200	20(1)	55	110	165	275	460	20(1)	45	90	135	225	370
1250	-	-	-	-	-	-	-	-	-	-	-	-
1300	-	-	-	-	-	-	-	-	-	-	-	-
1350	-	-	-	-	-	-	-	-	-	-	-	-
1400	-	-	-	-	-	-	-	-	-	-	-	-
1450	-	-	-	-	-	-	-	-	-	-	-	-
1500	-	-	-	-	-	-	-	-	-	-	-	-

# Pressure Temperature Rate



## CLASS 150Lb/300Lb/600Lb/900Lb/1500Lb/2500Lb PRESSURE TEMPERATURE RATE PSI (Psig)

Fahrenheit temperature	A217 C12						A351 CF3(f) A351 CF8					
	150Lb	300Lb	600Lb	900Lb	1500Lb	2500Lb	150Lb	300Lb	600Lb	900Lb	1500Lb	2500Lb
-20 to 100	290	750	1500	2250	3750	6250	275	720	1440	2160	3600	6000
200	260	750	1500	2250	3750	6250	235	600	1200	1800	3000	5000
300	230	730	1455	2185	3640	6070	205	530	1055	1585	2640	4400
400	200	705	1410	2115	3530	5880	180	470	940	1410	2350	3920
500	170	665	1330	1995	3325	5440	170	435	875	1310	2185	3640
600	140	605	1210	1815	3025	5040	140	415	830	1245	2075	3460
650	125	590	1175	1765	2940	4905	125	410	815	1225	2040	3400
700	110	570	1135	1705	2840	4730	110	405	805	1210	2015	3360
750	95	530	1065	1595	2660	4430	95	400	795	1195	1990	3320
800	80	510	1015	1525	2540	4230	80	395	790	1180	1970	3280
850	65	485	975	1460	2435	4060	65	390	780	1165	1945	3240
900	50	450	900	1350	2245	3745	50	385	770	1150	1920	3200
950	35	370	740	1110	1850	6085	35	375	750	1125	1870	3120
1000	20	290	585	875	1460	2430	20	325	645	965	1610	2685
1050	20(1)	190	380	565	945	1570	20(1)	310	620	925	1545	2570
1100	20(1)	115	225	340	565	945	20(1)	260	515	770	1285	2145
1150	20(1)	75	150	225	380	630	20(1)	195	390	585	980	1630
1200	20(1)	50	105	155	260	430	20(1)	155	310	465	770	1285
1250	-	-	-	-	-	-	20(1)	110	220	330	550	915
1300	-	-	-	-	-	-	20(1)	85	165	245	410	685
1350	-	-	-	-	-	-	20(1)	65	125	185	310	515
1400	-	-	-	-	-	-	20(1)	50	95	145	240	400
1450	-	-	-	-	-	-	15(1)	35	70	105	170	285
1500	-	-	-	-	-	-	10(1)	20	50	70	120	200

## CLASS 150Lb/300Lb/600Lb/900Lb/1500Lb/2500Lb PRESSURE TEMPERATURE RATE PSI (Psig)

Fahrenheit temperature	A351 CF3M(g) A351 CF8M						A351 CF8C						A351 CN7M(I)					
	150Lb	300Lb	600Lb	900Lb	1500Lb	2500Lb	150Lb	300Lb	600Lb	900Lb	1500Lb	2500Lb	150Lb	300Lb	600Lb	900Lb	1500Lb	2500Lb
-20 to 100	275	720	1440	2160	3600	6000	275	720	1440	2160	3600	6000	230	600	1200	1800	3000	5000
200	240	620	1240	1860	3095	5160	240	635	1270	1910	3180	5300	215	555	1115	1670	2785	4640
300	215	560	1120	1680	2795	4660	215	590	1175	1765	2940	4900	200	525	1045	1570	2615	4360
400	195	515	1030	1540	2570	4280	195	555	1110	1665	2770	4620	185	480	960	1445	2405	4010
500	170	480	955	1435	2390	3980	170	520	1035	1555	2590	4320	170	470	935	1405	2340	3900
600	140	450	905	1355	2255	3760	140	490	985	1475	2460	4100	140	455	910	1365	2275	3790
650	125	445	890	1330	2220	3700	125	480	960	1440	2400	4000	125	450	900	1350	2250	3750
700	110	430	865	1295	2160	3600	110	470	935	1405	2340	3900	110	445	890	1335	2225	3710
750	95	425	845	1270	2110	3520	95	460	920	1385	2305	3840	95	440	880	1320	2200	3665
800	80	415	830	1245	2075	3460	80	455	910	1370	2280	3800	80	430	865	1295	2160	3600
850	65	405	810	1215	2030	3380	65	445	890	1330	2220	3700	-	-	-	-	-	-
900	50	395	790	1180	1970	3280	50	430	865	1295	2160	3600	-	-	-	-	-	-
950	35	385	775	1160	1930	3220	35	385	775	1160	1930	3220	-	-	-	-	-	-
1000	20	265	725	1090	1820	3030	20	365	725	1090	1820	3030	-	-	-	-	-	-
1050	20(1)	360	720	1080	1800	3000	20(1)	360	720	1080	1800	3000	-	-	-	-	-	-
1100	20(1)	325	645	965	1610	2685	20(1)	325	645	965	1610	2685	-	-	-	-	-	-
1150	20(1)	275	550	825	1370	2285	20(1)	275	550	825	1370	2285	-	-	-	-	-	-
1200	20(1)	205	410	620	1030	1715	20(1)	170	345	515	855	1430	-	-	-	-	-	-
1250	20(1)	180	365	545	910	1515	20(1)	125	245	370	615	1030	-	-	-	-	-	-
1300	20(1)	140	275	410	685	1145	20(1)	95	185	280	465	770	-	-	-	-	-	-
1350	20(1)	105	205	310	515	860	20(1)	70	135	205	345	570	-	-	-	-	-	-
1400	20(1)	75	150	225	380	630	20(1)	50	105	155	255	430	-	-	-	-	-	-
1450	25(1)	62	115	175	290	485	20(1)	40	80	125	205	345	-	-	-	-	-	-
1500	15(1)	40	85	125	205	345	15(1)	35	70	105	170	285	-	-	-	-	-	-

# Butt-welding ends



## ANSI/ASME B 16.25

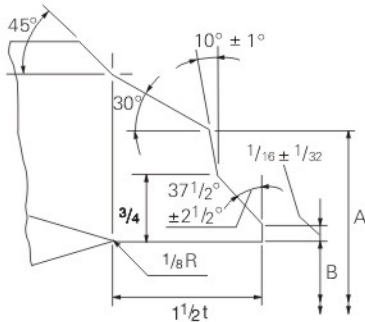
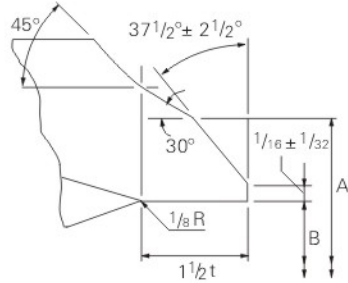

Figures refer to ANSI B 16-25

Important: When ordering butt welding end valves please state the type of ends required and give the pipe dimensions or schedule number.

STD=Standard wall thickness  
XS=Extra strong wall thickness  
XXS=Double extra strong wall thickness

All dimensions given in inches  
Designations per ANSI B 16.25

Nominal pipe size	Nominal pipe OD	Schedule Number	Valve OD A	Nominal ID B	Wall thickness of pipe T
2 1/2	73.025	40	73.025	5.156	62.713
		80		7.010	59.004
		160		9.525	53.975
		XXS		14.021	44.983
3	88.900	40	253.206	5.486	77.927
		80		7.620	73.660
		160		11.125	66.650
		XXS		15.240	58.420
4	114.300	40	142.875	6.020	102.260
		80		8.560	97.180
		120		11.125	92.050
		160		13.487	87.325
5	141.300	40	811.213	17.120	80.061
		80		6.553	128.194
		120		9.525	122.250
		160		12.700	115.900
6	168.275	40	496.094	15.875	109.550
		80		7.112	150.200
		120		10.973	146.329
		160		14.275	139.725
8	219.075	40	654.844	18.263	177.825
		60		8.179	202.717
		80		10.312	198.450
		100		12.700	193.675
10	273.050	40	1611.313	15.088	188.900
		60		12.700	182.550
		80		15.088	182.550
		100		18.263	177.825
12	323.850	40	977.106	20.625	222.250
		60		9.525	254.508
		80		12.700	247.650
		100		15.088	242.875
14	355.600	40	355.600	18.263	236.525
		60		12.700	230.175
		80		15.088	222.250
		100		18.263	215.900
16	406.400	40	406.400	25.400	304.800
		60		9.525	303.225
		80		12.700	298.450
		100		14.275	295.275
18	457.200	40	457.200	17.475	288.925
		60		25.400	273.050
		80		28.575	266.700
		100		33.325	257.200
20	508.000	40	508.000	33.325	336.550
		60		9.525	333.375
		80		11.125	330.200
		100		12.700	325.425
24	609.600	40	609.600	15.088	317.500
		60		19.050	307.950
		80		23.825	300.025
		100		27.788	292.100
28	687.500	40	687.500	31.750	284.175
		60		35.712	284.175
		80		9.525	387.350
		100		12.700	381.000
32	787.400	40	787.400	16.662	373.075
		60		21.438	363.55
		80		26.187	345.025
		100		30.963	344.475
36	897.300	40	897.300	36.525	333.350
		60		40.488	325.425
		80		14.275	428.650
		100		19.050	419.100
40	1007.200	40	1007.200	23.825	409.550
		60		29.362	398.475
		80		34.925	387.350
		100		39.675	377.850
48	1207.100	40	1207.100	45.237	366.725
		60		15.088	477.825
		80		20.625	466.750
		100		26.187	455.625
56	1407.000	40	1407.000	32.537	442.925
		60		38.100	431.800
		80		44.450	419.100
		100		50.013	407.975
64	1606.900	30	1606.900	14.275	581.050
		40		17.475	574.650
		60		24.613	560.375
		80		30.963	547.675
72	1806.800	40	1806.800	38.887	531.825
		60		46.025	517.550
		80		52.375	504.850
		100		59.538	490.525



# Flange Dimensions

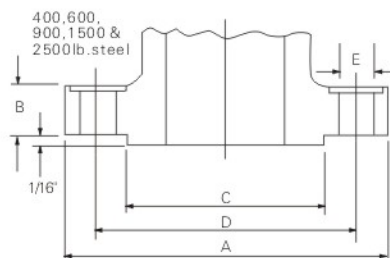
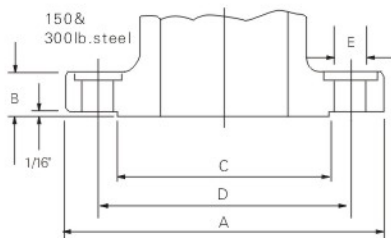

And flange dimensions comply with  
ANSI/ASME B 16.5 and MSS-SP-44  
All dimensions are in inches

	Nominal Pipe Size	Flange Diameter A	Flange Thickness	Diameter of Raised Face C	Diameter of Bolt Circle D	Diameter of Bolt Holes E	Number Of Bolts	Diameter of Bolts	
ANSI 600	1/2	95.250	14.288	34.925	66.675	15.875	4	12.700	The regular 1/4-inch raised face of 600 lb. Flanges is not included in the minimum flange thickness given. The bolt holes, which are in multiples of four, are drilled to straddle the centerline unless otherwise ordered.
	3/4	117.475	15.875	42.863	82.550	19.050	4	15.875	
	1	123.825	17.463	50.800	88.900	19.050	4	15.875	
	1 1/4	133.350	20.638	63.500	98.425	19.050	4	15.875	
	1 1/2	155.575	22.225	73.025	114.300	22.225	4	19.050	
	2	165.100	25.400	92.075	127.000	19.050	8	15.875	
	2 1/2	190.500	28.575	104.775	149.225	22.225	8	19.050	
	3	104.775	31.750	127.000	168.275	22.225	8	19.050	
	3 1/2	228.600	34.925	139.700	184.150	25.400	8	22.225	
	4	273.050	38.100	157.163	215.900	25.400	8	22.225	
	5	330.200	44.450	185.738	266.700	28.575	8	25.400	
	6	355.600	47.625	215.900	292.100	28.575	12	25.400	
	8	419.100	53.563	269.875	353.375	31.750	12	28.575	
	10	508.000	63.500	273.050	431.800	34.925	16	31.750	
	12	558.800	66.675	381.000	488.950	34.925	20	31.750	
	14	603.250	69.850	412.750	527.050	38.100	20	34.925	
	16	685.800	76.200	469.900	603.250	41.275	20	38.100	
	18	742.950	82.550	533.400	654.050	44.450	20	41.275	
	20	812.800	88.900	584.200	723.900	44.450	24	47.275	
	24	939.800	101.600	692.150	838.200	50.800	24	47.625	
	26	1016.000	107.950	749.300	914.400	50.800	28	47.625	
	28	1073.150	111.125	800.100	965.200	53.975	28	50.800	
	30	1130.300	114.300	857.250	1022.350	53.975	28	50.800	
32	1193.800	117.475	914.400	1079.500	60.325	28	57.150		
34	1244.600	120.650	965.200	1130.300	60.325	28	57.150		
36	1301.750	123.825	107.950	1193.800	66.675	28	63.500		
ANSI 900	3	241.300	38.100	127.000	190.500	25.400	8	22.225	Use 1500 lb. Dimensions in sizes smaller than 3-inch.
	4	292.100	44.450	157.163	234.950	31.750	8	28.575	
	5	349.250	50.800	185.738	279.400	34.925	8	31.750	
	6	371.000	55.563	215.900	317.500	31.750	12	28.575	
	8	469.900	63.500	269.875	393.700	38.100	12	34.925	
	10	546.100	69.850	323.850	469.900	38.100	16	34.925	
	12	609.600	79.375	381.000	533.400	38.100	20	34.925	
	14	641.350	85.725	412.750	558.800	41.275	20	38.100	
	16	704.850	88.900	469.900	615.950	44.450	20	41.275	
	18	787.400	101.600	533.400	685.800	50.800	20	47.625	
	20	857.250	107.950	584.200	749.300	53.975	20	50.800	
24	1041.400	139.700	692.150	901.700	66.675	20	63.500		
ANSI 1500	1/2	120.650	22.225	34.925	82.550	22.225	4	19.050	The regular 1/4-inch raised face of 900 and 1500 lb. flange is not included in the minimum flange thickness given. The bolt holes, which are in multiples of four, are drilled to straddle the centerline unless otherwise ordered.
	3/4	141.275	25.400	42.863	88.900	22.225	4	19.050	
	1	149.225	28.575	50.800	101.600	25.400	4	22.225	
	1 1/4	158.750	28.575	63.500	111.125	25.400	4	22.225	
	1 1/2	177.800	31.750	82.550	123.825	28.575	4	25.400	
	2	215.900	38.100	92.075	165.100	25.400	8	22.225	
	2 1/2	244.475	41.275	104.775	190.500	28.575	8	25.400	
	3	266.700	47.625	127.000	203.200	31.750	8	28.575	
	4	311.150	53.975	157.163	241.300	34.925	8	31.750	
	5	374.650	73.025	185.738	292.100	41.275	8	38.100	
	6	393.700	82.550	215.900	317.500	38.100	12	34.925	
	8	482.600	92.075	269.875	393.700	44.450	12	41.275	
	10	584.200	107.950	323.850	482.600	50.800	12	47.625	
	12	673.100	123.825	381.000	571.500	53.975	16	50.800	
	14	749.300	133.350	412.750	635.000	60.325	16	57.150	
	16	825.500	146.050	469.900	704.850	66.675	16	63.500	
	18	914.400	161.925	533.400	774.700	73.025	16	69.850	
	20	984.250	177.800	584.200	831.850	79.375	16	76.200	
24	1168.400	203.200	692.150	990.600	92.075	16	88.900		
ANSI 2500	1/2	133.350	30.163	34.925	88.900	22.225	4	19.050	The regular 1/4-inch raised face of 2500 lb. flanges is not included in the minimum flange thickness given. The bolt holes, which are in multiples of four, are drilled to straddle the centerline unless otherwise ordered.
	3/4	139.700	31.750	42.863	95.250	22.225	4	19.050	
	1	158.750	34.925	50.800	107.950	25.400	4	22.225	
	1 1/4	184.150	38.100	63.500	130.175	28.575	4	25.400	
	1 1/2	203.200	44.450	73.025	146.050	31.750	4	28.575	
	2	234.950	50.800	92.075	171.450	28.575	8	25.400	
	2 1/2	266.700	57.150	104.775	196.850	31.750	8	28.575	
	3	304.800	65.888	127.000	228.600	34.925	8	31.750	
	4	355.600	76.200	157.163	273.050	41.275	8	38.100	
	5	419.100	92.075	185.738	323.850	47.625	8	44.450	
	6	482.600	107.950	215.900	368.300	53.975	8	50.800	
	8	552.450	127.000	269.875	438.150	59.975	12	50.800	
	10	673.100	165.100	323.850	539.750	66.675	12	63.500	
12	762.000	184.150	381.000	619.125	73.025	12	69.850		

# Ring Joint Facings



## ANSI/ASME B 16.5 AND B 16.20

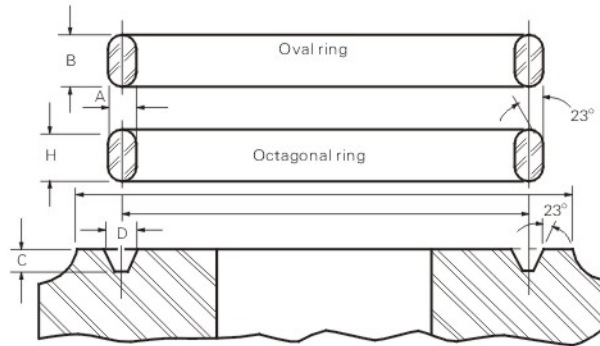

Groove suitable for either oval or octagonal ring

	Nominal Pipe Size	Ring Number	Ring Width A	Oval Ring Height B	Groove Width D	Octagonal Ring Height H	Ring Join Raised Face Diameter K	Groove Depth L	Ring & Groove Pitch Diameter P	
	1	R15	7.938	14.288	8.731	12.700	63.500	6.350	47.625	
	1 1/4	R17	7.938	14.288	8.731	12.700	73.025	6.350	57.150	
	1 1/2	R19	7.938	14.288	8.731	12.700	82.550	6.350	65.088	
	2	R22	7.938	14.288	8.731	12.700	101.600	6.350	82.550	
	2 1/2	R25	7.938	14.288	8.731	12.700	120.650	6.350	101.600	
	3	R29	7.938	14.288	8.731	12.700	133.350	6.350	114.300	
	4	R36	7.938	14.288	8.731	12.700	171.450	6.350	149.225	
	5	R40	7.938	14.288	8.731	12.700	193.675	6.350	171.450	
	6	R43	7.938	14.288	8.731	12.700	219.075	6.350	193.675	
	8	R48	7.938	14.288	8.731	12.700	273.050	6.350	247.650	
	10	R52	7.938	14.288	8.731	12.700	330.200	6.350	304.800	
	12	R56	7.938	14.288	8.731	12.700	406.400	6.350	381.000	
	14	R59	7.938	14.288	8.731	12.700	425.450	6.350	396.875	
	16	R64	7.938	14.288	8.731	12.700	482.600	6.350	454.025	
	18	R68	7.938	14.288	8.731	12.700	546.100	6.350	517.525	
	20	R72	7.938	14.288	8.731	12.700	596.900	6.350	558.800	
	24	R76	7.938	14.288	8.731	12.700	711.200	6.350	673.100	
		1/2	R11	6.350	11.113	7.144	9.525	50.800	5.556	34.131
		3/4	R13	7.938	14.288	8.731	12.700	63.500	6.350	42.863
		1	R16	7.938	14.288	8.731	12.700	69.850	6.350	50.800
		1 1/4	R18	7.938	14.288	8.731	12.700	79.375	6.350	60.325
		1 1/2	R20	7.938	14.288	8.731	12.700	90.488	6.350	68.263
		2	R23	11.113	17.463	11.906	15.875	107.950	7.938	82.550
		2 1/2	R26	11.113	17.463	11.906	15.875	127.000	7.938	101.600
3		R31	11.113	17.463	11.906	15.875	146.050	7.938	123.825	
4		R37	11.113	17.463	11.906	15.875	174.625	7.938	149.225	
5		R41	11.113	17.463	11.906	15.875	209.550	7.938	180.975	
6		R45	11.113	17.463	11.906	15.875	241.300	7.938	211.138	
8		R49	11.113	17.463	11.906	15.875	301.625	7.938	269.875	
10		R53	11.113	17.463	11.906	15.875	355.600	7.938	323.850	
12		R57	11.113	17.463	11.906	15.875	412.750	7.938	381.000	
14		R61	11.113	17.463	11.906	15.875	457.200	7.938	419.100	
16		R65	11.113	17.463	11.906	15.875	508.000	7.938	469.900	
18		R69	11.113	17.463	11.906	15.875	574.675	7.938	533.400	
20		R73	12.700	19.050	13.494	17.463	635.000	9.525	584.200	
24		R77	15.875	22.225	16.669	20.638	749.300	11.113	692.150	



# Ring Joint Facings



	Nominal Pipe Size	Ring Number	Ring Width A	Oval Ring Height B	Groove Width D	Octagonal Ring Height H	Ring Joint Raised Face Diameter K	Groove Depth L	Ring & Groove Pitch Diameter P
<b>900 LB.</b>	3	R31	11.113	17.463	11.906	15.875	155.575	7.938	123.825
	4	R37	11.113	17.463	11.906	15.875	180.975	7.938	149.225
	5	R41	11.113	17.463	11.906	15.875	215.900	7.938	180.975
	6	R45	11.113	17.463	11.906	15.875	241.300	7.938	211.138
	8	R49	11.113	17.463	11.906	15.875	307.975	7.938	269.875
	10	R53	11.113	17.463	11.906	15.875	361.950	7.938	323.850
	12	R57	11.113	17.463	11.906	15.875	419.100	7.938	381.000
	14	R62	15.875	22.225	16.669	20.638	466.725	11.113	419.100
	16	R66	15.875	22.225	16.669	20.638	523.875	11.113	469.900
	18	R70	19.050	25.400	19.844	23.813	593.725	12.700	533.400
	20	R74	19.050	25.400	19.844	23.813	647.700	12.700	584.200
	24	R78	25.400	33.338	26.988	31.750	771.525	15.875	692.150
<b>1500 LB.</b>	1/2	R12	7.938	14.288	8.731	12.700	60.325	6.350	39.688
	1/4	R14	7.938	14.288	8.731	12.700	60.325	6.350	44.450
	1	R16	7.938	14.288	8.731	12.700	71.438	6.350	50.800
	1 1/4	R18	7.938	14.288	8.731	12.700	80.963	6.350	60.325
	1 1/2	R20	7.938	14.288	8.731	12.700	92.075	6.350	68.263
	2	R24	11.113	17.463	11.906	15.875	123.825	7.938	95.250
	2 1/2	R27	11.113	17.463	11.906	15.875	136.525	7.938	107.950
	3	R35	11.113	17.463	11.906	15.875	168.275	7.938	136.525
	4	R39	11.113	17.463	11.906	15.875	193.675	7.938	161.925
	5	R44	11.113	17.463	11.906	15.875	228.600	7.938	193.675
	6	R46	12.700	19.050	13.494	17.463	247.650	9.525	211.138
	8	R50	15.875	22.225	16.669	20.638	317.500	11.113	269.875
	10	R54	15.875	22.225	16.669	20.638	371.475	11.113	323.850
	12	R58	22.225	28.575	23.019	26.988	438.150	14.288	381.000
	14	R63	25.400	33.338	26.988	31.750	488.950	15.875	419.100
	16	R67	28.575	36.513	30.163	34.925	546.100	17.463	469.900
	18	R71	28.575	36.513	30.163	34.925	612.775	17.463	533.400
	20	R75	31.750	39.688	33.338	38.100	673.100	17.463	584.200
24	R79	34.925	44.450	36.513	41.275	793.750	20.638	692.150	
<b>2500 LB.</b>	1/2	R13	7.938	14.288	8.731	12.700	65.088	6.350	42.863
	3/4	R16	7.938	14.288	8.731	12.700	73.025	6.350	50.800
	1	R18	7.938	14.288	8.731	12.700	82.550	6.350	60.325
	1 1/4	R21	11.113	17.463	11.906	15.875	101.600	7.938	548.481
	1 1/2	R23	11.113	17.463	11.906	15.875	114.300	7.938	82.550
	2	R26	11.113	17.463	11.906	15.875	133.350	7.938	101.600
	2 1/2	R28	12.700	19.050	13.494	17.463	149.225	9.525	111.125
	3	R32	12.700	19.050	13.494	17.463	168.275	9.525	127.000
	4	R28	15.875	22.225	16.669	20.638	203.200	11.113	157.163
	5	R42	19.050	25.400	19.844	23.813	241.300	12.700	190.500
	6	R47	19.050	25.400	19.844	23.813	279.400	12.700	228.600
	8	R51	22.225	28.575	23.019	26.988	339.725	14.288	279.400
	10	R55	28.575	36.513	30.163	34.925	425.450	17.463	342.900
	12	R60	31.750	39.688	33.338	38.100	495.300	17.463	406.400

All dimensions are in inches.

# Gate Valve

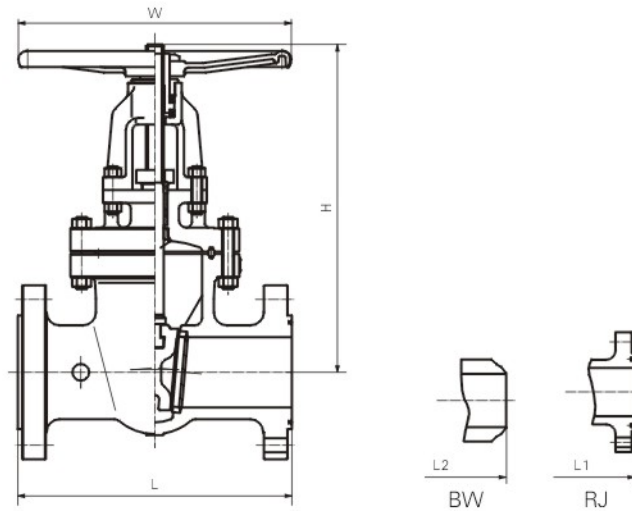

## CL900

Spec (NPS)	in	2	2 1/2	3	4	5	6	8	10	12	14	16	18	20	24
Face to face(mm)	L	368	419	381	457	559	610	737	838	965	1029	1130	1219	1321	1549
	L1	371	422	384	460	562	613	740	841	968	1039	1140	1232	1334	1568
	L2	368	419	381	457	559	610	737	838	965	1029	1130	1219	1321	1549
Center height(mm)	H	445	480	513	613	730	834	875	1040	1150	1360	1520	1830	2100	2610
Hand wheel diameter(mm)	W	300	300	350	400	500	600	600	650	700	-	-	-	-	-
Weight (Kg)		72	101	130	197	285	404	650	1376	1177	1500	1920	-	-	-

## CL1500

Spec (NPS)	in	2	2 1/2	3	4	5	6	8	10	12	14	16	18	20	24
Face to face(mm)	L	368	419	470	546	673	705	832	991	1130	1257	1384	1537	1664	1943
	L1	371	422	473	549	676	711	842	1001	1146	1276	1406	1559	1686	1971
	L2	368	419	470	546	673	705	832	911	1130	1257	1384	1537	1664	1943
Center height(mm)	H	462	512	550	752	927	1120	1390	1524	1850	2180	2210	-	-	-
Hand wheel diameter(mm)	W	300	350	400	550	550	600	700	800	-	-	-	-	-	-
Weight (Kg)		85	130	170	304	-	646	1100	1600	2106	2700	3500	-	-	-

## CL2500

Spec (NPS)	in	2	2 1/2	3	4	5	6	8	10	12	14	16	18	20	24
Face to face(mm)	L	451	508	578	673	794	914	1022	1270	1422					
	L1	454	514	584	683	807	927	1038	1292	1444					
	L2	451	508	578	673	794	914	1022	1270	1422					
Center height(mm)	H	520	630	730	880	1020	1120	1350	1600	1900					
Hand wheel diameter(mm)	W	300	350	400	500	600	700	800	-	-					
Weight (Kg)		-	-	-	-	-	-	-	-	-					

# Gate Valves



PZ<sup>5</sup><sub>9</sub> 41Y TYPE

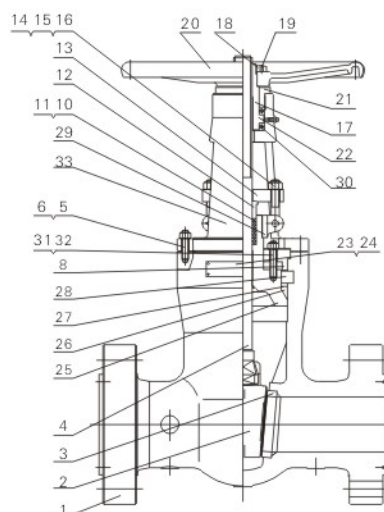

## MAIN PARTS MATERIAL SHEET

Item	Part name	WCB	C5	WC6	CF8	CF8M
1	Body	A216 WCB	A217 C5	A217 WC6	A351 CF8	A351 CF8M
2	Wedge disc	A216 WCB/STL.6	A217 C5/STL.6	A217 WC6/STL.6	A351 CF8	A351 CF8M
3	Seat	A105/STL.6	A182 F11/STL.6	182 F11/STL.6	A182 F304	A182 F316
4	Stem	A182 F6a	A182 F6a	A182 F6a	A182 F304	A182 F316
5	Bolt	A193 B7	A193 B7	A193 B7	A193 B8	A193 B8M
6	Nut	A194 2H	A194 2H	A194 2H	A194 8	A194 8M
8	Bonnet	A216 WCB	A216 WCB	A216 WCB	A351 CF8	A351 CF8
10	Packing	304+flexible graphite				Pillar 6610+6528
11	Distance ring	A182 F6a	A182 F6a	A182 F6a	A182 F304	A182 F316
12	Packing gland	A182 F6a	A182 F6a	A182 F6a	A182 F304	A182 F316
13	Packing plate	A216 WCB	A216 WCB	A216 WCB	A351 CF8	A351 CF8
14	Eye bolt	A193 B7	A193 B7	A193 B7	A193 B8	A193 B8
15	Nut	A194 2H	A194 2H	A194 2H	A194 8	A194 8
16	Pin	1035	1035	1035	304	304
17	Stem bolt	A439 Type D2	A439 Type D2	A439 Type D2	A439 Type D2	A439 Type D2
18	Locking nut	1035	1035	1035	1035	1035
19	Locking screw	1035	1035	1035	1035	1035
20	Hand wheel	AISI 1118	AISI 1118	AISI 1118	AISI 1118	AISI 1118
21	Bearing gland	1035	1035	1035	1035	1035
22	Oil cup	Finished product	Finished product	Finished product	Finished product	Finished product
23	Nameplate	AISI 304	AISI 304	AISI 304	AISI 304	AISI 304
24	Rivet	AL	AL	AL	AL	AL
25	Pressure seal seat	A216 WCB	A217 C5	A217 WC6	A351 CF8	A351 CF8M
26	Pressure seal gasket	304+flexible graphite				
27	Pressure seal ring	A182 F6a	A182 F6a	A182 F6a	A182 F304	A182 F316
28	Segment ring	A182 F6a	A182 F11	A182 F11	A182 F304	A182 F316
29	Hanger Roke	A216 WCB	A216 WCB	A216 WCB	A351 CF8	A351 CF8
30	Bearing	40Cr	40Cr	40Cr	40Cr	40Cr
31	Hanger bolt	A193 B7	A193 B7	A193 B7	A193 B8	A193 B8M
32	Nut	A194 2H	A194 2H	A194 2H	A194 8	A194 8M
33	Roke	A216 WCB	A216 WCB	A216 WCB	A351 CF8	A351 CF8

Note: the distance ring should be installed if user require

# Gate Valve

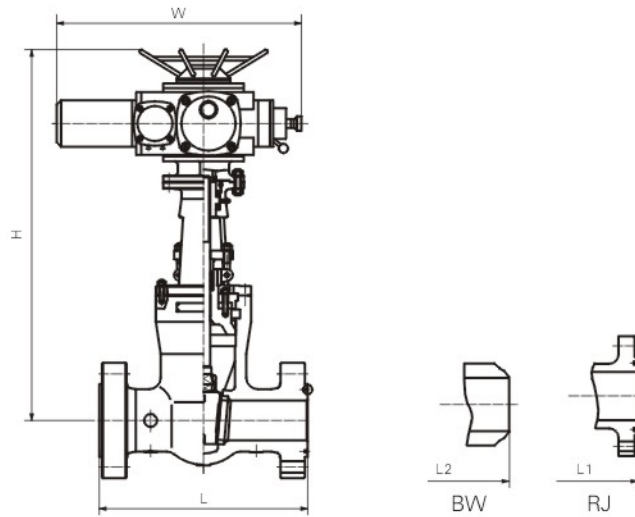

## CL900

Spec (NPS)	in	2	2 1/2	3	4	6	8	10	12	14	16
Face to face(mm)	L	368	419	381	457	610	737	838	965	1029	1130
	L1	371	422	384	460	613	740	841	968	1039	1140
	L2	216	254	305	356	508	660	787	914	991	1092
Center height(mm)	H	445	252	660	666	928	-	-	-	-	-
Hand wheel diameter(mm)	W	300	300	350	400	600	-	-	-	-	1960
Weight (Kg)		50	74	90	110	195	505	745	1060	1410	-

## CL1500

Spec (NPS)	in	2	2 1/2	3	4	6	8	10	12	14	16
Face to face(mm)	L	368	419	470	546	705	832	991	1130	1257	1384
	L1	371	422	473	549	711	842	1001	1146	1276	1406
	L2	216	254	305	406	559	711	864	991	1067	1104
Center height(mm)	H	485	554	672	768	-	-	-	-	-	-
Hand wheel diameter(mm)	W	300	350	400	560	-	-	-	-	-	-
Weight (Kg)		50	74	90	158	350	690	1030	1460	1810	2760

## CL2500

Spec (NPS)	in	2	2 1/2	3	4	6	8	10	12	14	16
Face to face(mm)	L	451	508	578	673	914	1022	1270	1422		
	L1	454	514	584	683	927	1038	1292	1444		
	L2	279	330	368	457	610	762	914	1041		
Center height(mm)	H	594	753	840	880	-	-	-	-		
Hand wheel diameter(mm)	W	350	400	560	600	-	-	-	-		
Weight (Kg)		60	100	110	200	530	750	1610	3010		

# Globe valve



Btl globe valve usually be reliably used in steam, air, coal gas, oil or oil gas etc high or low-pressure condition. Middle or low pressure valve normal adopt taper disc sealing structure, but the large diameter and high pressure valve adopt sideway disc sealing structure, the medium flow from high to low position, it use medium self pressure seal, so the sealing is very reliable and the operated torque is more light. According to condition, the valve can be apply more kinds of material and connection type between bonnet and body and can be reach to more requirements of user.



## ◆ CAST STEEL GLOBE VALVE DESIGN STRUCTURE AND FEATURE

Design and manufacture conform to ASME16.34 & BS 1873, Test and check conform to API 598.

### ◆ ADOPT THE FOLLOWING STRUCTURE

Taper sealing disc or soft sealing structure  
Self-centering gland or plate Renewable seat  
Bolted bonnet, spiral would eight-square gasket sealing  
bonnet or pressure seal bonnet

### ◆ ACCORDING TO THE FOLLOWING STANDARD

Flange ends conform to ASME B 16.5  
Butt-welding end conform to ASME B 16.25  
Face to face dimension conform to ASME B 16.10  
Operation type: electrical, pneumatic, hydraulic and gear drive etc